



911376-00

98/9947

VON DUPRIN®

Concealed Vertical Rod Exit Device  
Metal Door Applications

Installation Instructions

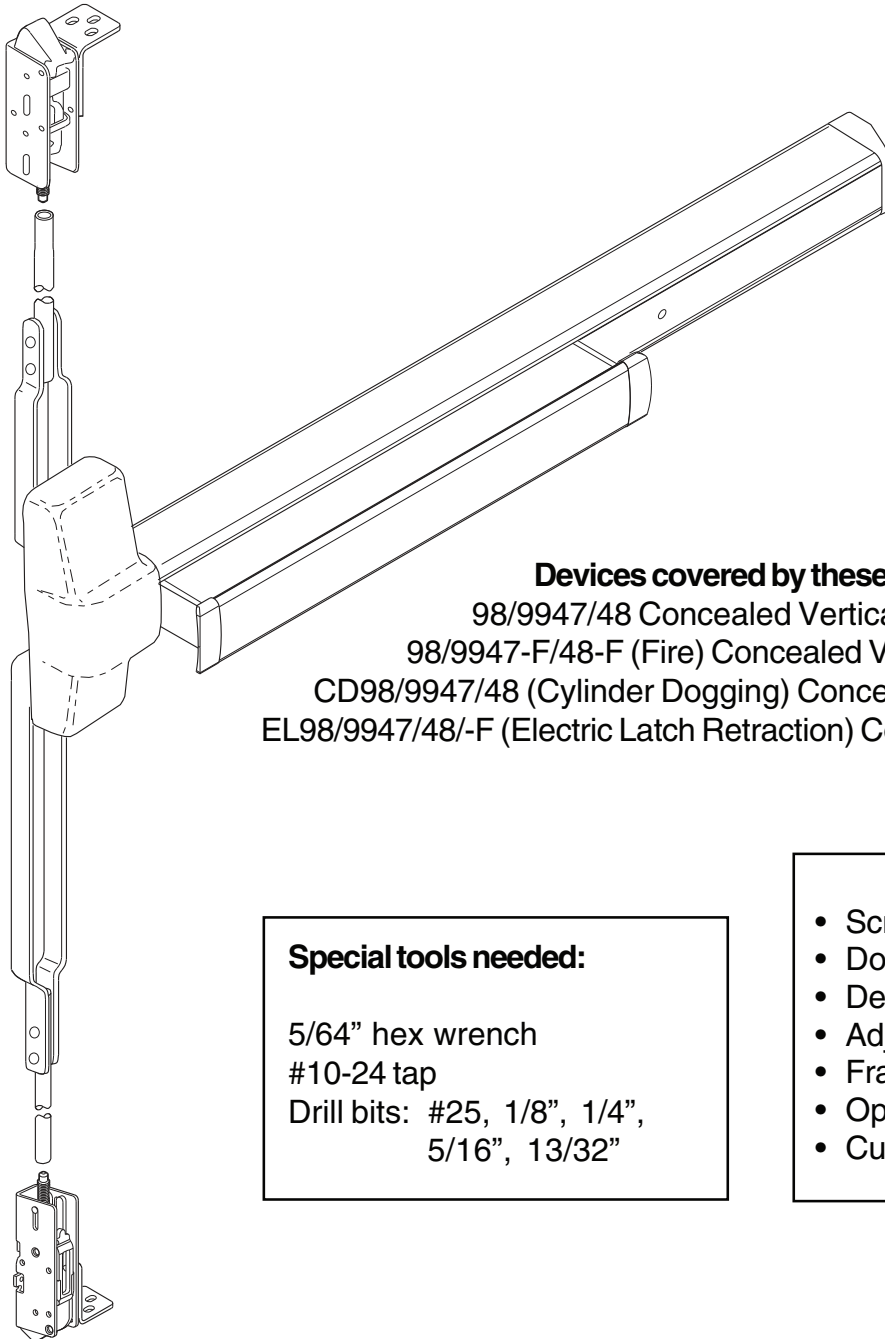

**Devices covered by these instructions:**

- 98/9947/48 Concealed Vertical Rod Exit Device
- 98/9947-F/48-F (Fire) Concealed Vertical Rod Exit Device
- CD98/9947/48 (Cylinder Dogging) Concealed Vertical Rod Exit Device
- EL98/9947/48/-F (Electric Latch Retraction) Concealed Vertical Rod Exit Device

**Special tools needed:**

5/64" hex wrench  
 #10-24 tap  
 Drill bits: #25, 1/8", 1/4",  
 5/16", 13/32"









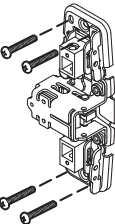
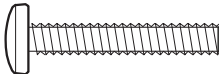
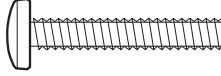
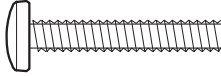
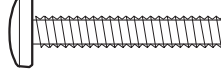
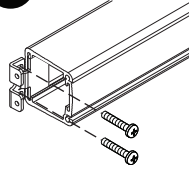
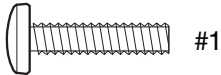
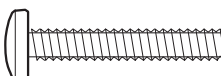

**Index:**

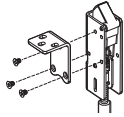
- Screw chart ..... 2
- Door preparation chart ..... 3
- Device installation ..... 4-6
- Adjust rods ..... 7
- Frame preparation chart ..... 7
- Optional equipment ..... 8
- Cut device ..... 8

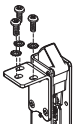
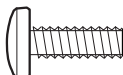
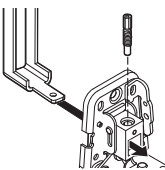
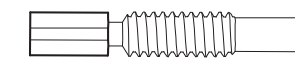
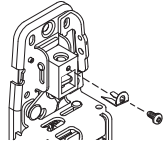

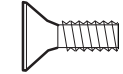
**Customer Service**  
 1-877-671-7011    www.allegion.com/us

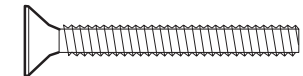
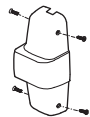
# SCREW CHART

<p><b>A</b></p> 	 #10-24 x 1"	Surface mount or Sex bolts (1-3/4" door)
	 #10-24 x 1-1/2"	Sex bolts (2-1/4" door)
	- Packaged with trim -	
	 #10-24 x 1-3/8"	990 trims (1-3/4" door)
	 #10-24 x 1-7/8"	990 trims (2-1/4" door)
<p><b>B</b></p> 	 #10-24 x 3/4"	Surface mount or Sex bolts (1-3/4" door)
	 #10-24 x 1-1/8"	Sex bolts (2-1/4" door)
<p><b>C</b></p> 	 #10-16 X 3/8" Thread cutting	End cap
<p><b>D</b></p> 	 #10-32 X 1/4"	Bracket to latch
<p><b>E</b></p> 	 #10-24 X 1/2"	Bracket to door
<p><b>F</b></p> 	 Rod adjusting screw	Retaining clip
<p><b>G</b></p> 	 #8-32 X 5/16"	Retaining clip
<p><b>H</b></p> 	 #10-24 X 1/2"	338 strike
<p><b>I</b></p> 	 #10-24 X 1-1/2"	Ratchet release
<p><b>J</b></p> 	 #8-18 x 3/8" Thread cutting	Center case cover

# DOOR PREPARATION CHART

Go to instructions on next page before using preparation chart

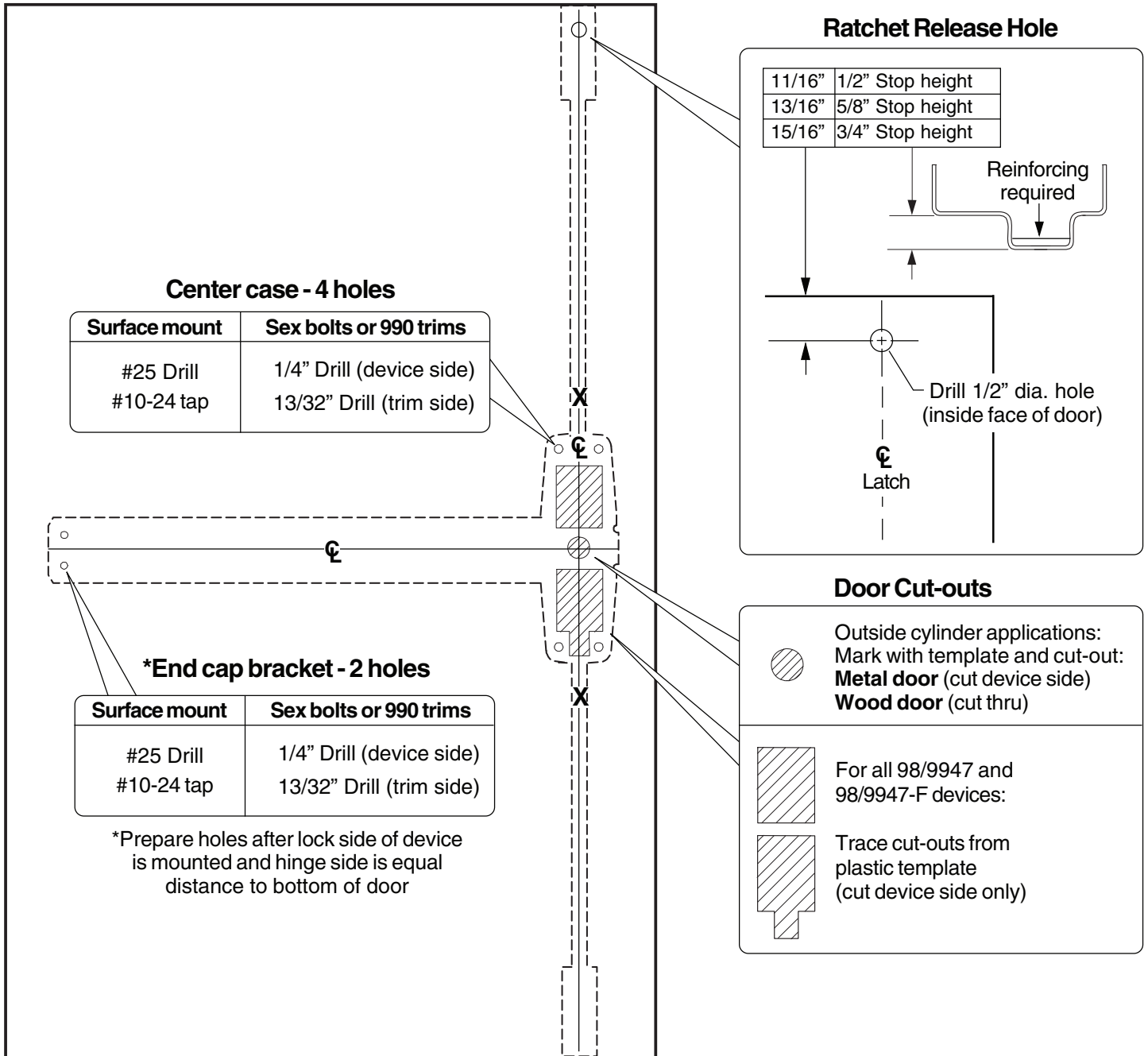

## Latch Cases

(Drill top and bottom of door)

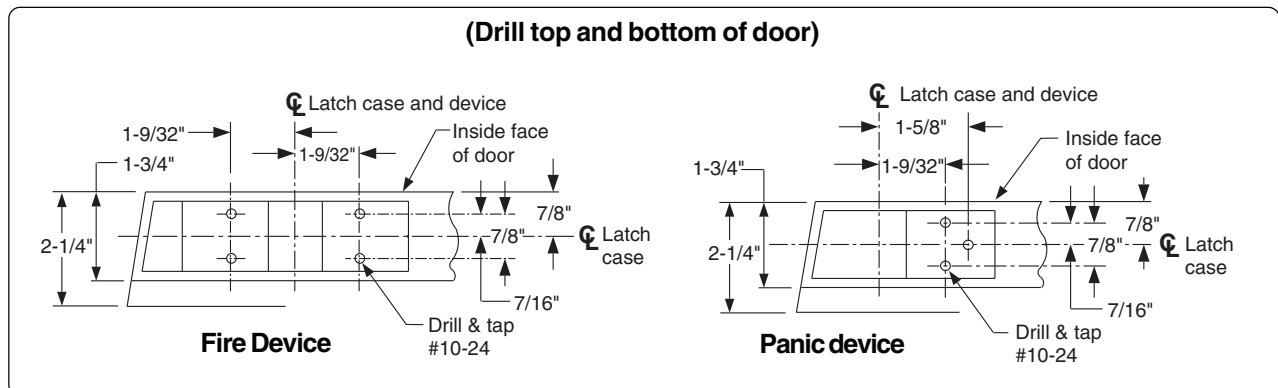

**1** Draw Horizontal Device Center Line (☉)

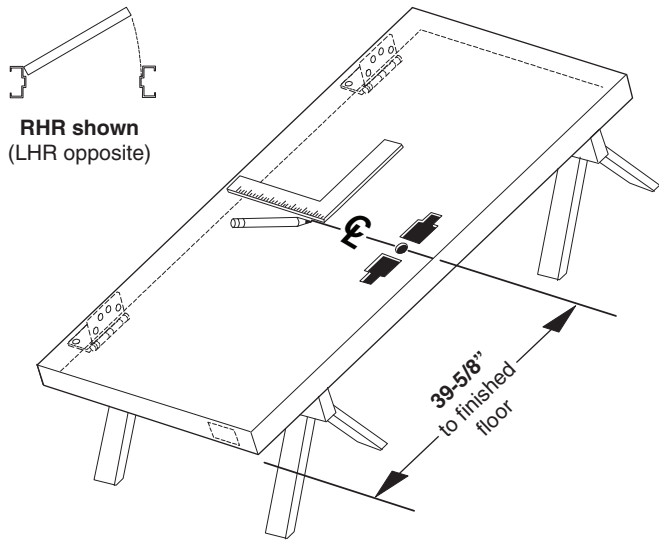

**3** Prepare Door per Preparation Chart on Page 3

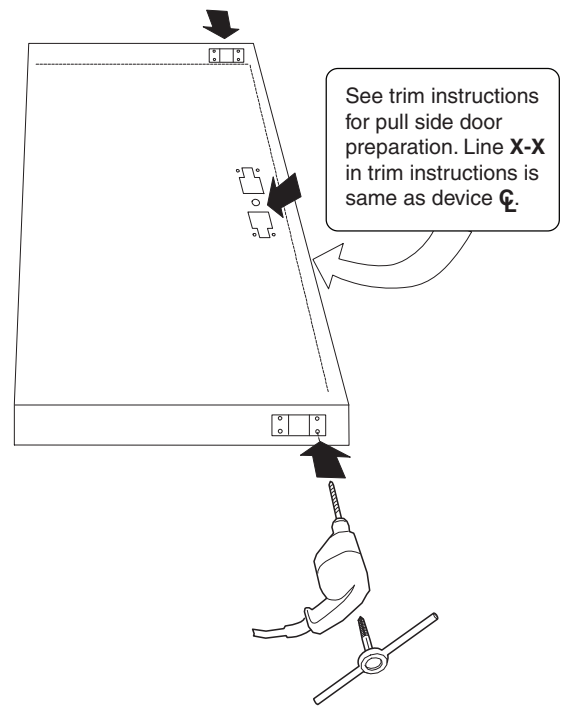

**2** Determine Correct Backset, then Mark 4 Holes for Device Center Case Using Template

**98/9947**  
(non-fire rated device)  
single or double door

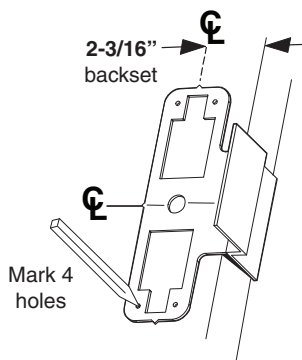

**98/9947-F**  
(fire rated device)  
or **98/9947**  
double door with  
98/9975 (mortise device)  
on opposite door

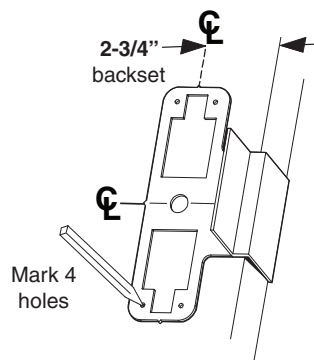

#### 4 If Necessary, Remove NL Drive Screw

##### NL drive screw

Factory installed on back of center case

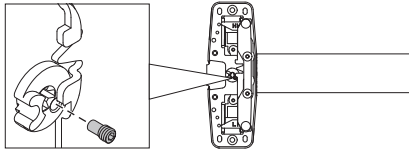

With the NL drive screw removed, key locks and unlocks lever, knob, or thumb piece. For the trims listed below, **REMOVE** NL drive screw.

996L 996K	696TP 697TP	990TP
--------------	----------------	-------

With the NL drive screw installed, key retracts latch bolt. **DO NOT** remove NL drive screw for the following applications:

NL, EO, DT trims and 98/99-2 double cylinder devices (i.e. TP-2, L-2, and K-2).

*996L-BE	*E996L	*696TP-BE	*990TP-BE
*996K-BE	*E996L-BE	*697TP-BE	

\* If the trim being installed is "BE" (i.e. 996L-BE), the trim lock tumbler on the back of the device must be in the **UP** position before device is installed. This allows the trim to be unlocked at all times.

trim lock tumbler in UP position

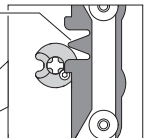
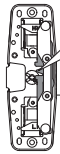

Correct Orientation (RHR shown)

If necessary, remove drive screw and rotate cam until trim lock tumbler is in UP position, then reinstall drive screw

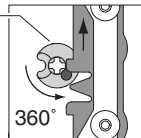

Incorrect Orientation

#### 5 If Using a Cylinder with a Tailpiece, Prepare Device and Cylinder

a. Install tailpiece guide.

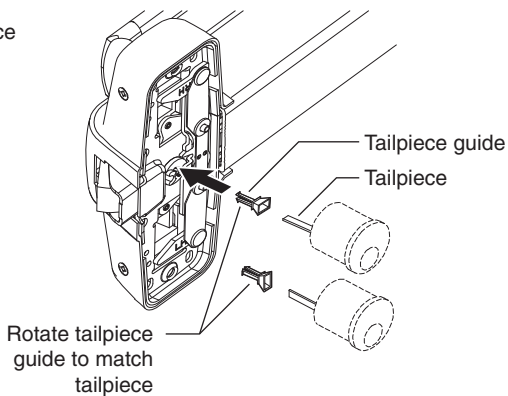

b. Cut tailpiece as needed.

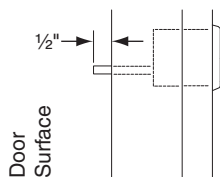

#### 6 Assemble Rods and Latches and Adjust Length for Proper Door Height

Follow red and blue instruction cards on rods to set initial rod length

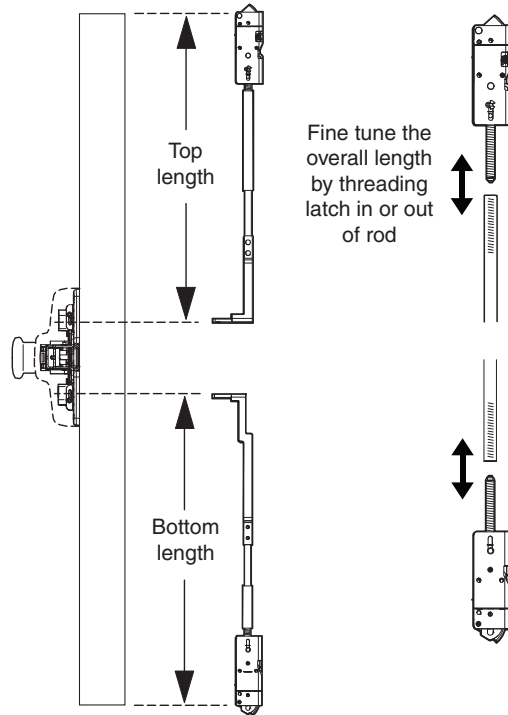

#### 7 Install Rods and Latches as Shown

Note: Fire devices use brackets on both sides of latches

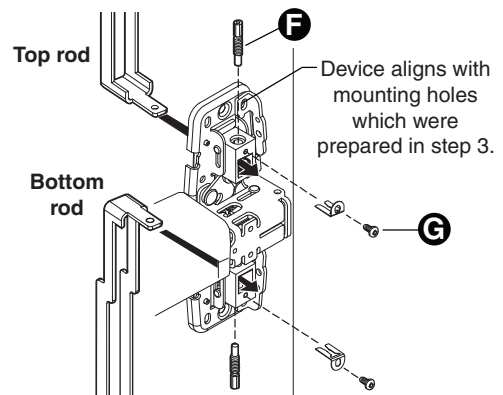
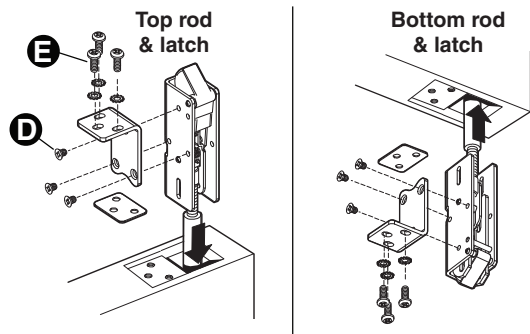

**8** Secure Device to Door as Shown, then Hang Door on Frame

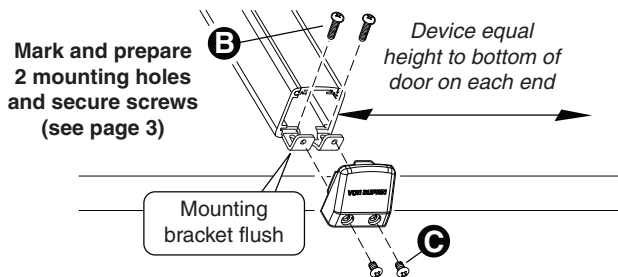
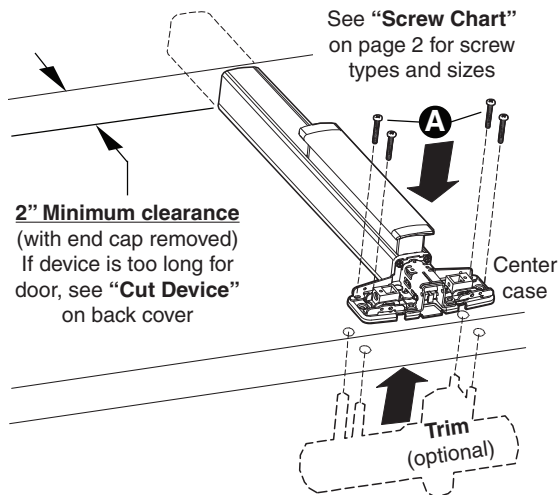

**10** Install Bottom Strike or Prepare Threshold

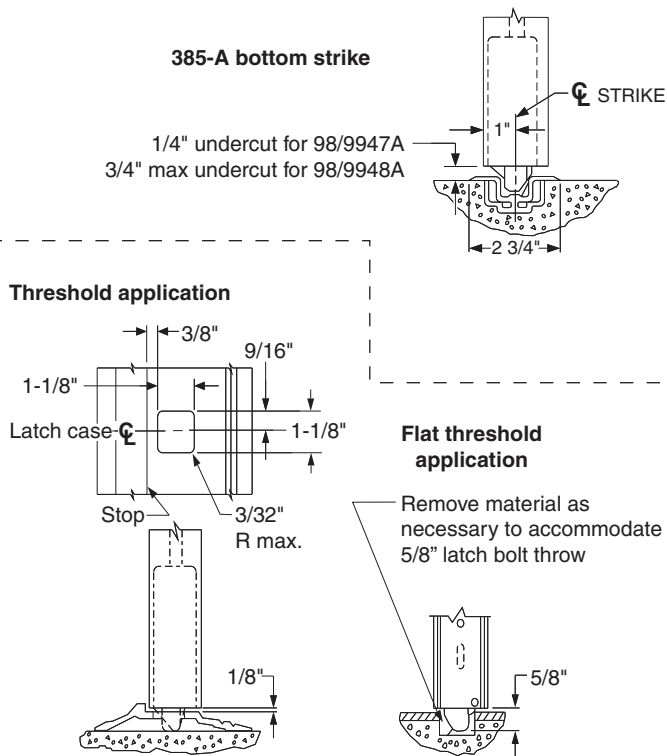

**9** Install Top Strike and Ratchet Release

338 Top strike

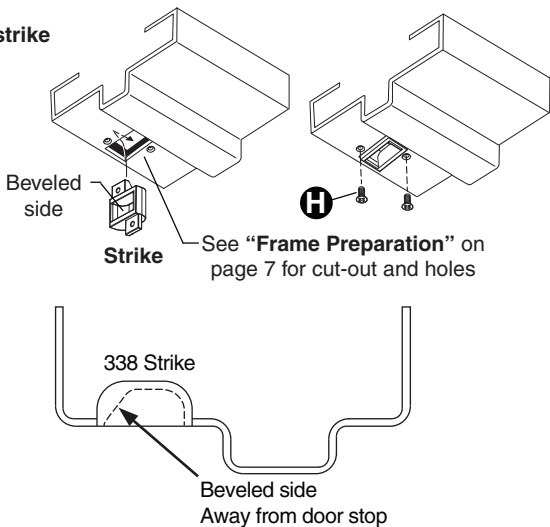

Ratchet release

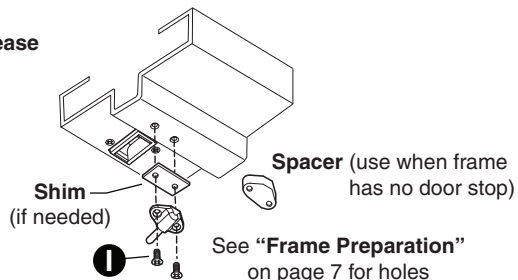

**11** Adjust Rods and Install Center Case Cover

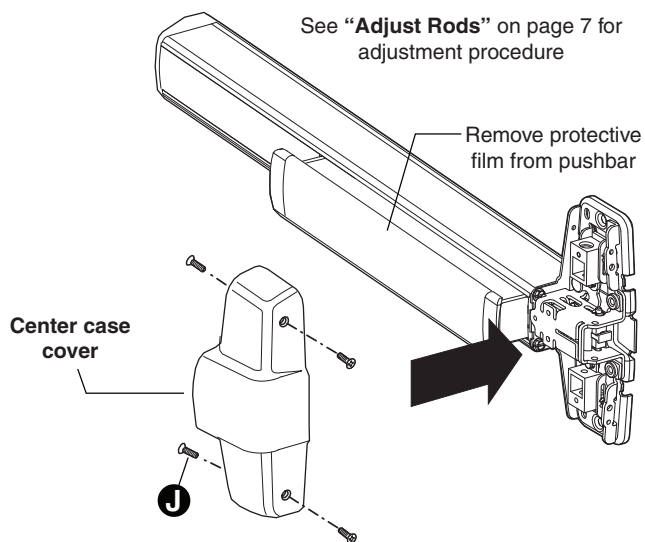

# ADJUST RODS

1. Open door and release top latch bolt as shown (Figure 1).

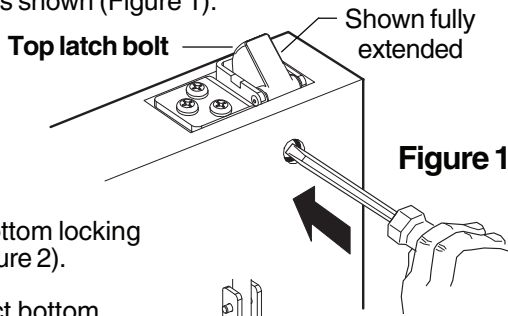

2. Loosen bottom locking screw (Figure 2).

3. Disconnect bottom vertical rod by removing bottom adjusting screw.

4. Loosen top locking screw.

5. Rotate top adjusting screw clockwise until top latch bolt is fully extended (Figure 1).

6. Check top latch bolt for deadlocking (latch bolt should not push in).

7. Turn top locking screw in. Do not over-tighten

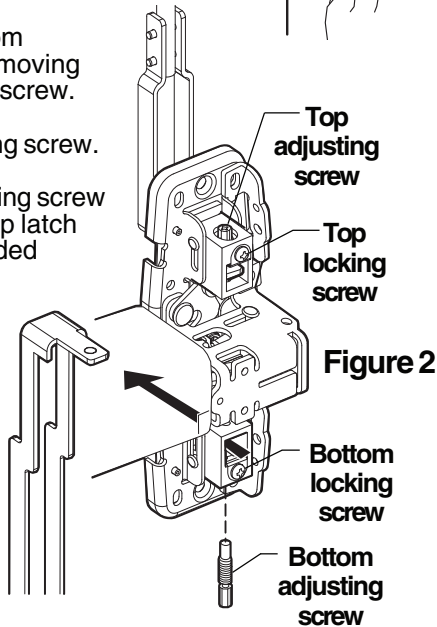

8. Depress pushbar and release.

9. Make sure top latch bolt stays retracted as shown.

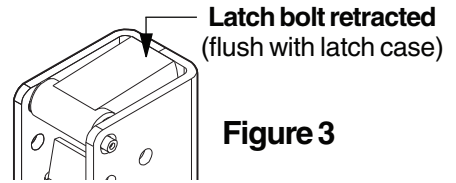

10. Install bottom adjusting screw through bottom rod (Figure 2).

11. With top latch bolt still retracted, adjust bottom rod so latch bolt clears floor and bottom strike.

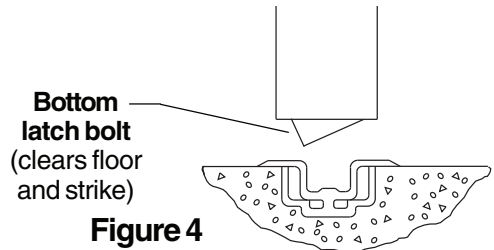

12. Turn bottom locking screw in. Do not over-tighten.
13. Check device operation by opening and closing door several times from the outside.

### Redo adjustment procedure if :

- Top latchbolt is not held retracted
- Bottom latchbolt does not clear floor and bottom strike

# FRAME PREPARATION

## TOPSTRIKE

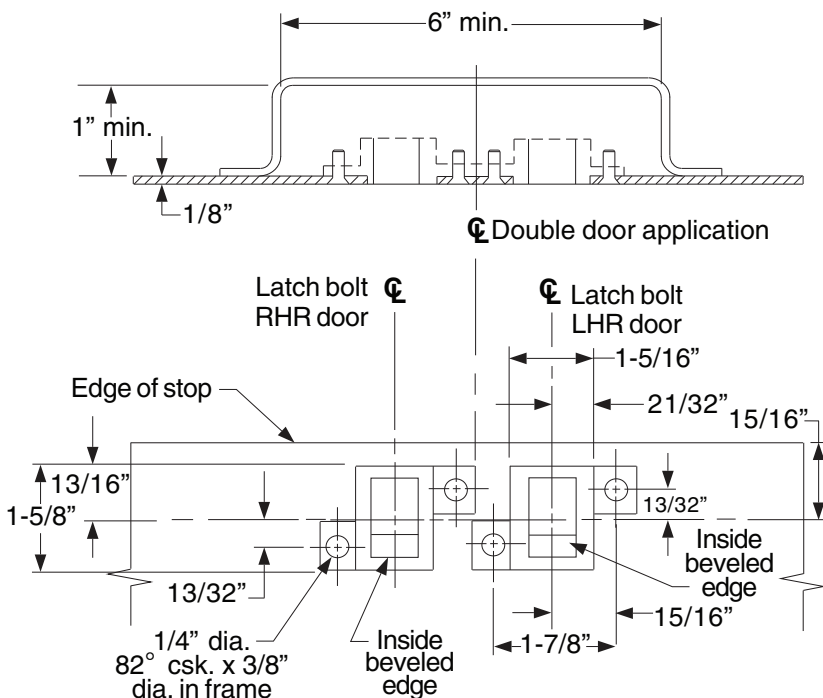

## RATCHET RELEASE

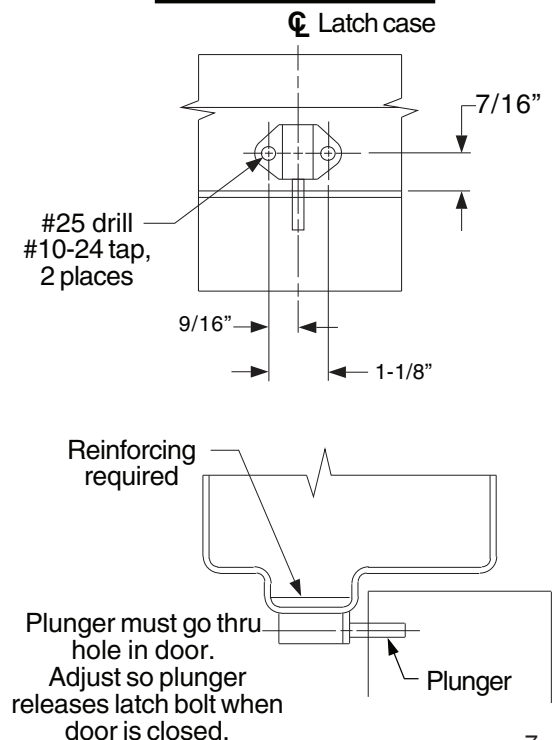

# OPTIONAL EQUIPMENT - CONTINUED

## CD (CYLINDER DOGGING)

1. Remove mortise cylinder cam and reinstall in reverse (Figure 6).
2. Insert key and rotate cam to install the cylinder to the cover plate (Figure 7).
3. Remove key to slide cover plate in position in the mechanism case.

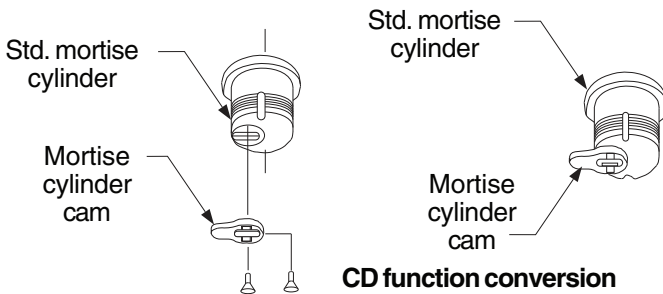

**Figure 6**

### Dogging procedure

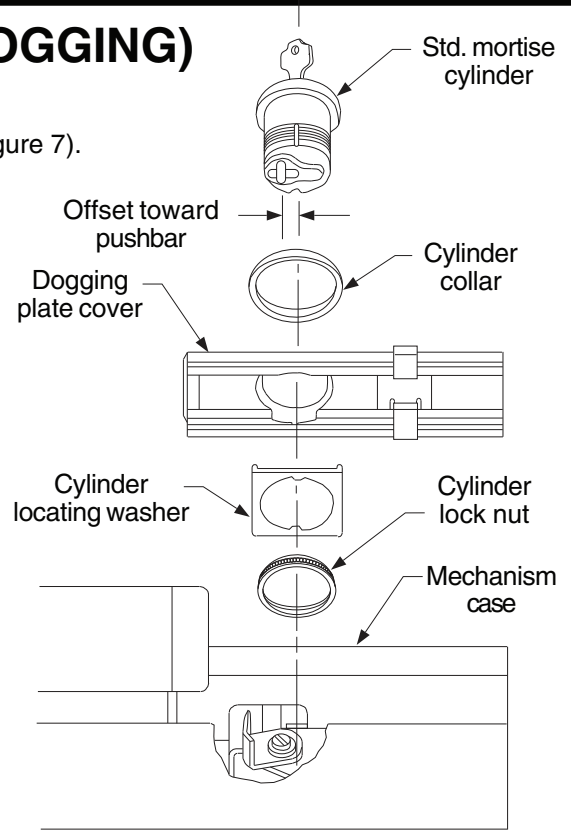
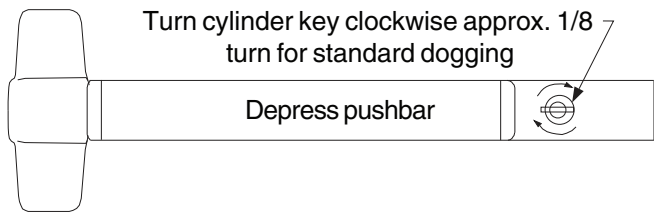

**Figure 7**

## CUT DEVICE

### 1 Measure amount to cut off device.

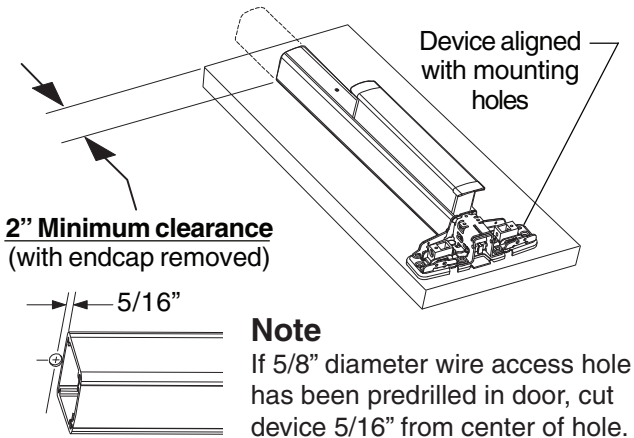

### 2 Tape and mark area being cut.

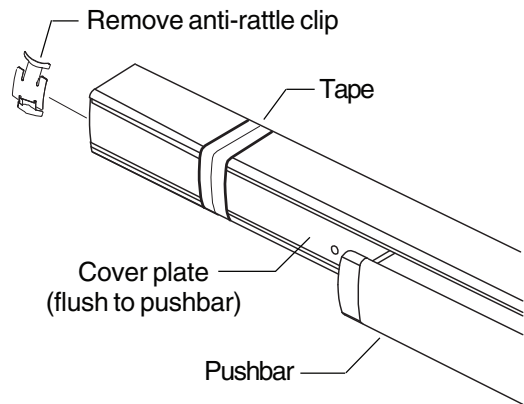

### 3 Cut device square.

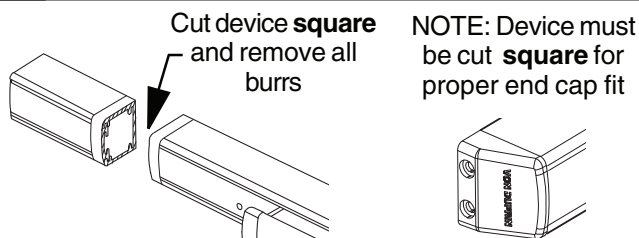

### 4 Slide anti-rattle clip into device.

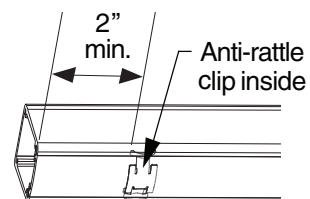





24908386

# QEL 33A/35A, 98/99 Series

# VON DUPRIN®

Conversion Kit

Installation Instructions



1. This kit converts all 33/35A and 98/99 series mechanical exit devices to quiet electric latch (QEL) retraction devices.
2. This kit can also be used for motor replacement on existing QEL devices.
3. Install according to instructions or device will not function and panic or fire label will be void.
4. The QEL wiring must be attached to the fire alarm system if installed on fire exit hardware.
5. If existing device is fire rated or less dogging a QEL baseplate conversion kit is required.

### Parts

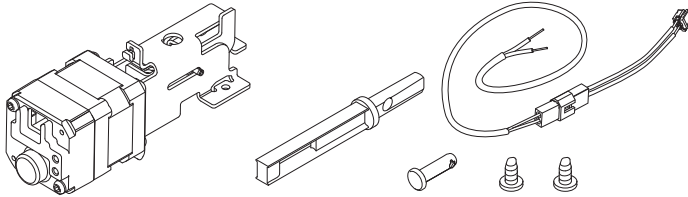

QEL

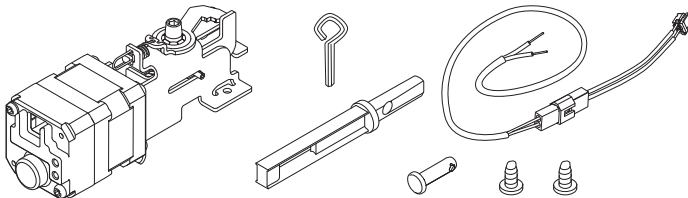

HD-QEL (Hex Dogging QEL)



**WARNING**

If existing exit device is fire rated, do not install HD-QEL (hex dogging) type motor. Doing so will void fire rating.

### 3 Remove Exit Device from Door

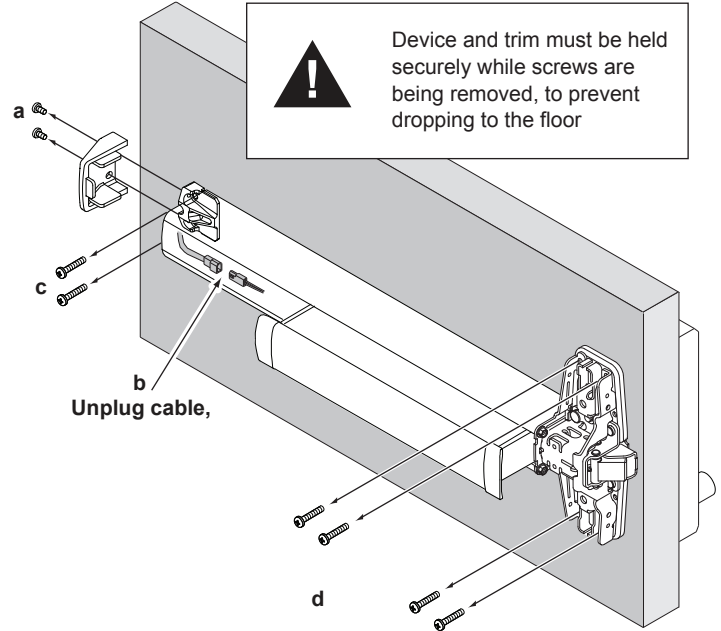

### 1 Disconnect Power

To avoid risk of shock, disconnect AC power from power supply before proceeding with this conversion. If using 900-BB Battery Backup option, unplug all four wires from battery terminals.

### 2 Detach Vertical Rods if present

Refer to device instructions as needed.

### 4 Remove Mechanism Case

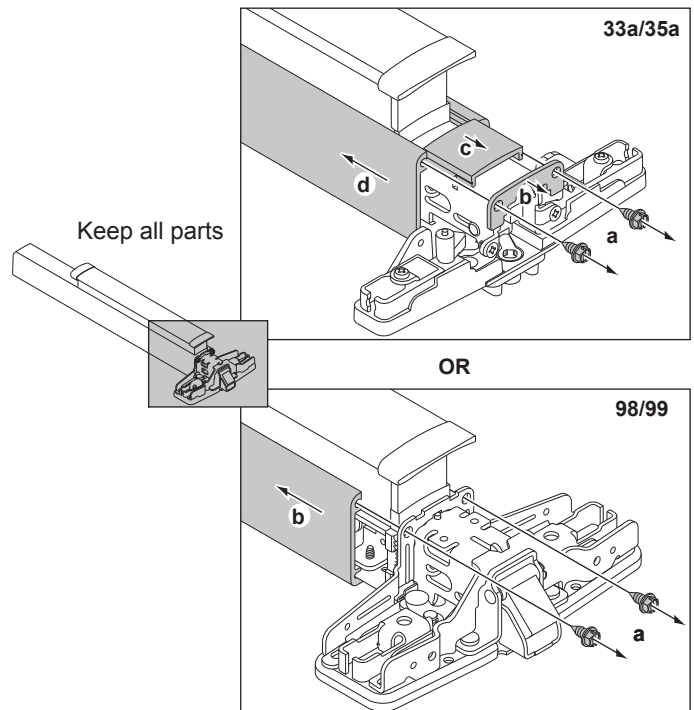

**5** Prepare baseplate for new motor. Find your existing application below (on page 2 or 3) and follow steps.

**FIRE OR LESS DOGGING DEVICE**  
(Applies to exit devices built after October 2014.  
Baseplate conversion kit required for earlier devices.)

1. Remove pushpad from baseplate.

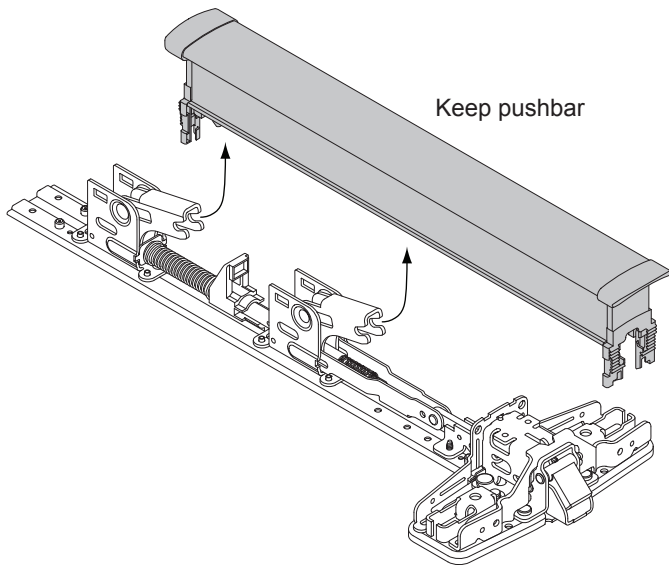

2. Install connector and pin.

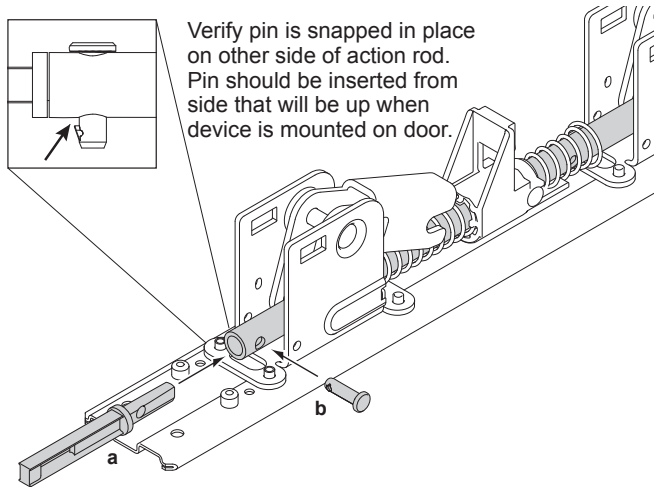

**QEL DEVICE (built prior to December 2014)**

1. Remove existing QEL motor

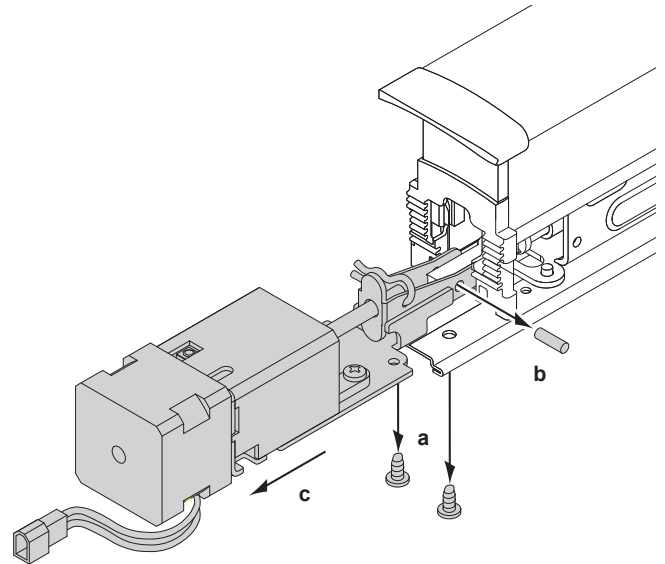

2. Discard old QEL motor assembly.

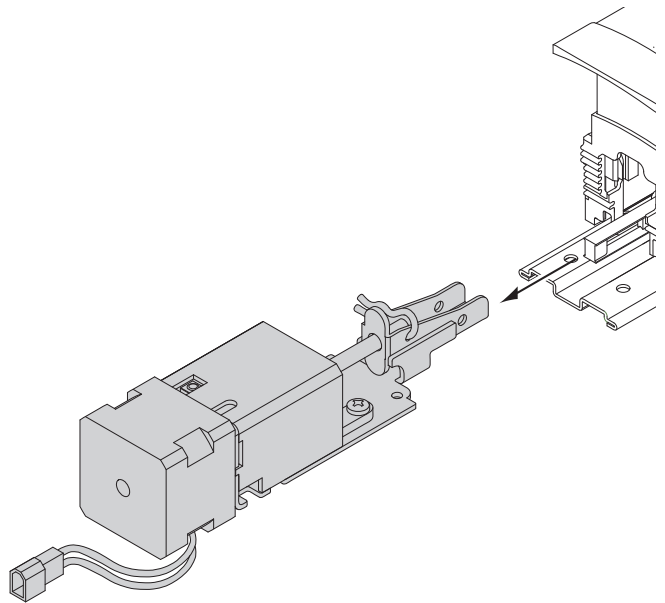

**QEL DEVICE (built after December 2014)**

1. Remove existing QEL motor.

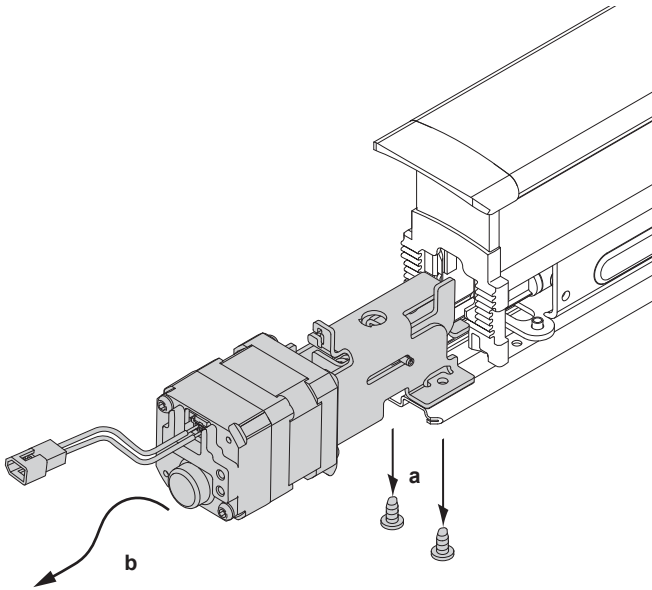

2. Discard old QEL motor assembly.

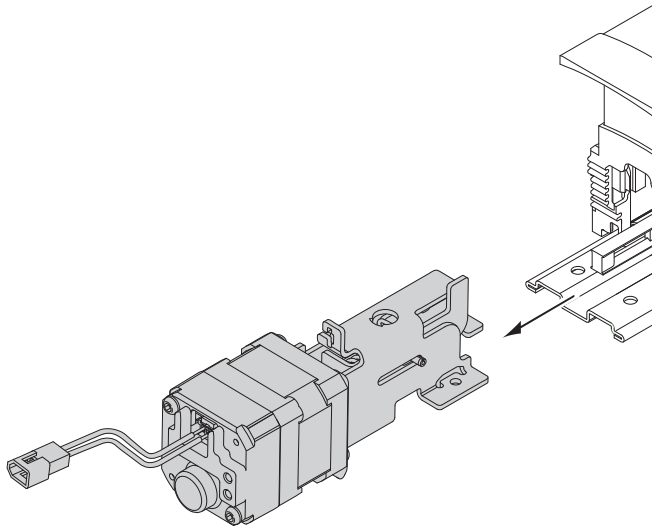

**PANIC DEVICE (with dogging assembly)**

1. Remove two screws from dogging assembly. If riveted see below.

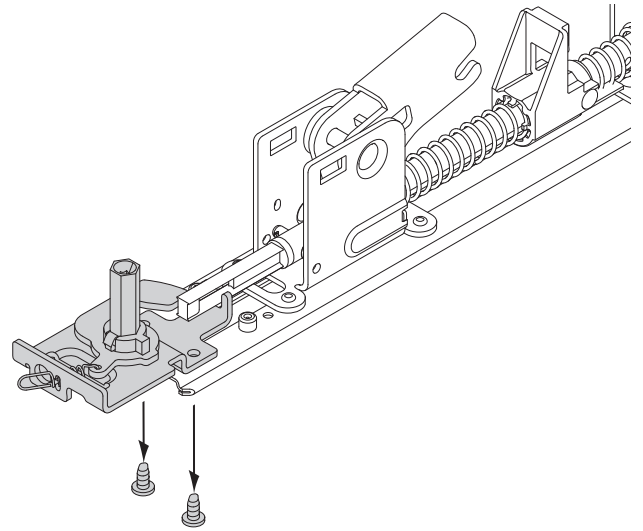

2. Drill or use center punch on two rivet heads until rivets can be removed from baseplate.

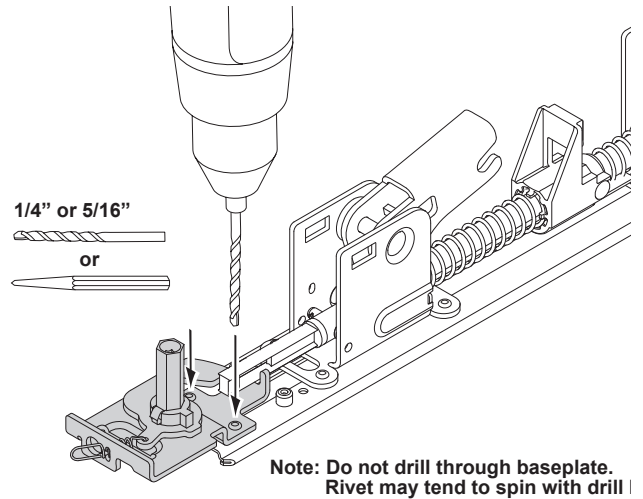

3. Remove and discard dogging assembly.

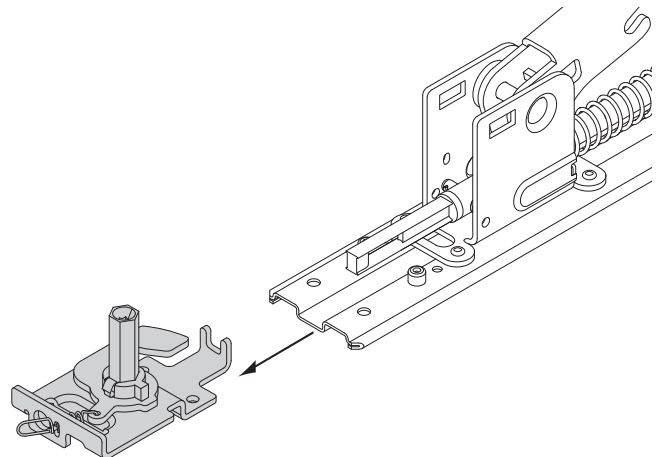

## 6 Install New QEL Motor Assembly

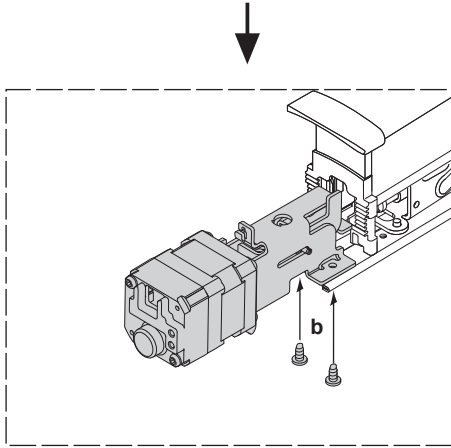
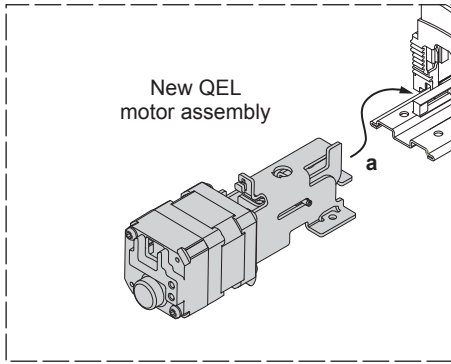

## 7 Install Mechanism Case

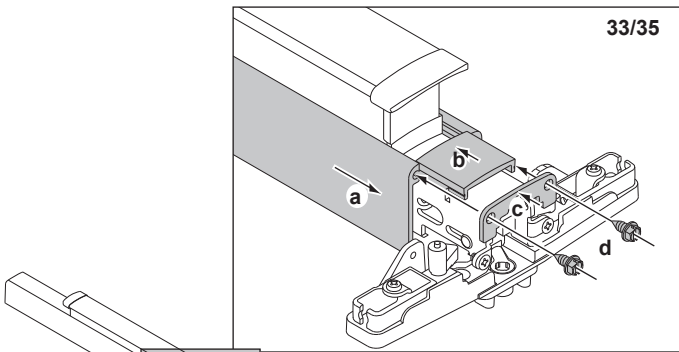

OR

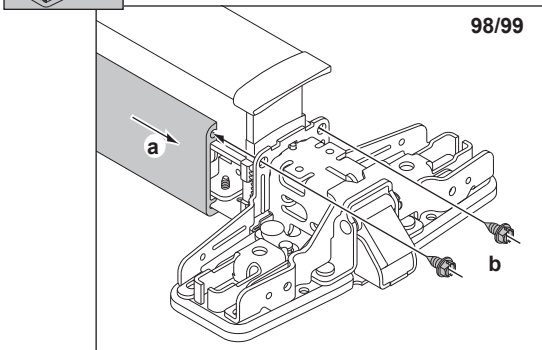

## 8 Prepare dogging cover for HD dogging key (if applicable and only on panic devices).

### 8a Locate and drill hole

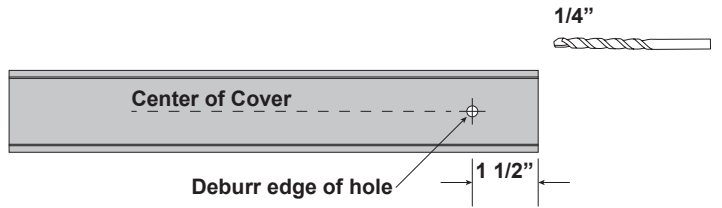

### 8b Install dogging cover

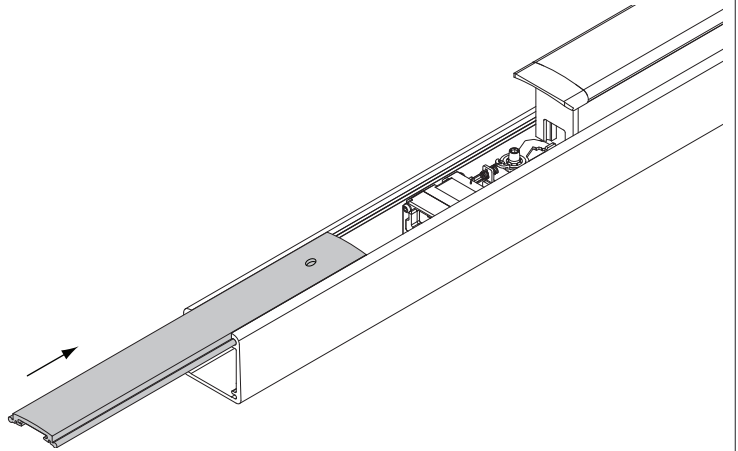

## 9 Drill Wire Access Hole (if required)

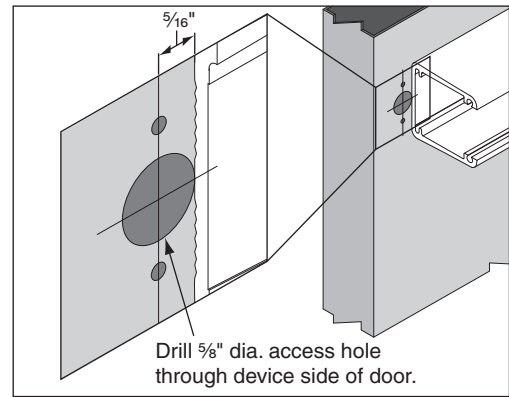

## 10 Attach Exit Device to Door

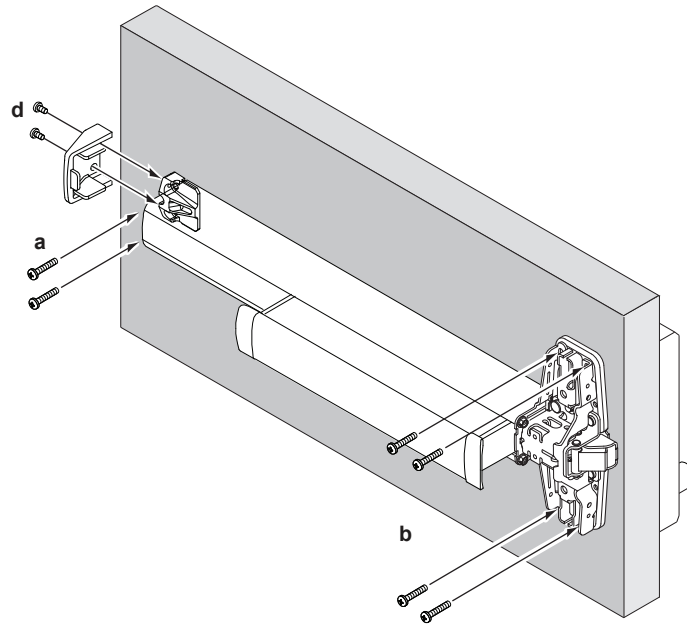

For more detailed installation instructions for specific Exit Devices, visit the Support area of the Allegion website at [www.allegion.com/us](http://www.allegion.com/us)

## 11 Confirm Equipment Compatibility

The QEL is compatible with the following equipment (refer to individual instructions as needed):

- PS900-SERIES Power Supplies - PS902, PS904, PS906, PS914
- 900-SERIES Option Boards - 900-2RS, 900-4R, 900-4RL, 900-2Q
- PS873 Power Supply Plus 871-2, 871-2Q, 873-4TD/AO Option Boards

## 12 Route Two Wires from QEL Exit Device to Power Supply

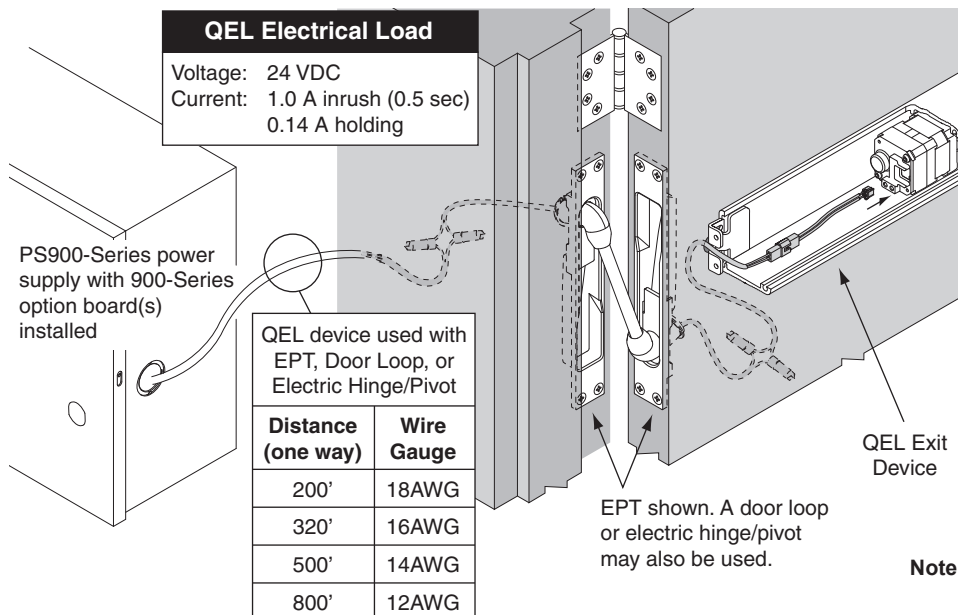

# 13 Install 900-2Rs, 4RI, or 4R Option Board(s) into Power Supply

## a Review Available 900 series Option Board Mounting Locations (Gray)

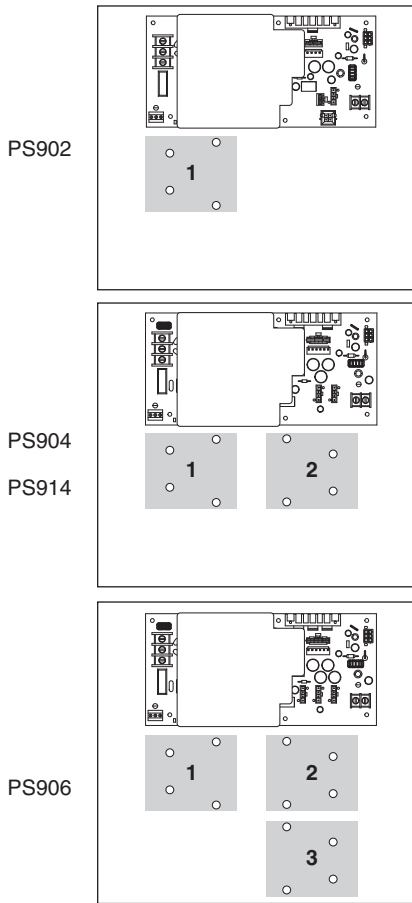

## b Plug Option Board Cable into any Available Option Connector

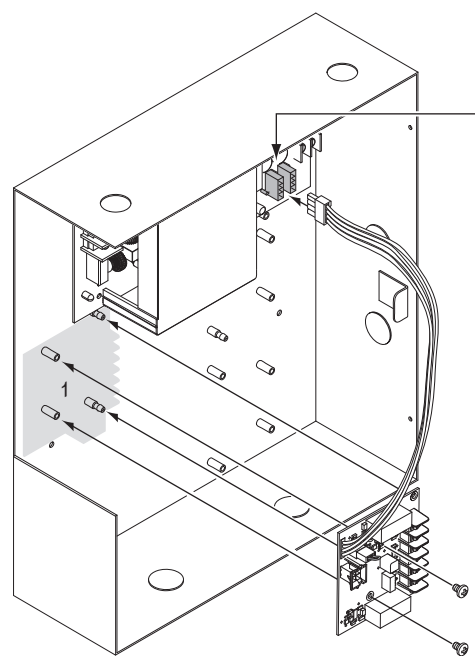
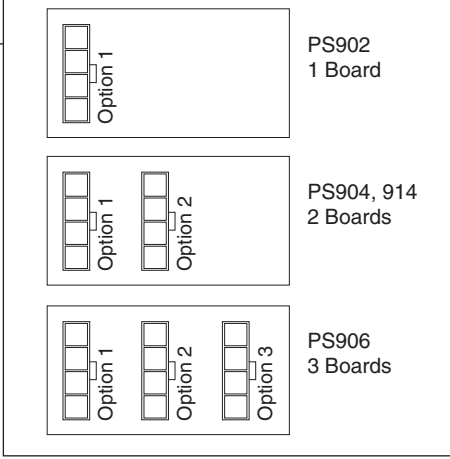

## c Secure Board(s) with Screws

- Notes:**
1. 24VDC output setting required when QEL device connected
  2. If installing board in location 2 or 3, rotate board 180°
  3. The QEL is compatible with an existing 900-2Q board if currently installed.
  4. Latchbolt retraction of (2) sequenced QEL's requires more than 1 second to complete.
  5. When powering multiple components, verify that the amperage requirements of all components combined does not exceed the power supply output rating.

# 14 Connect Input and Output Wires to Option Board (2RS Shown)

### Sequential Mode - Typical Wiring

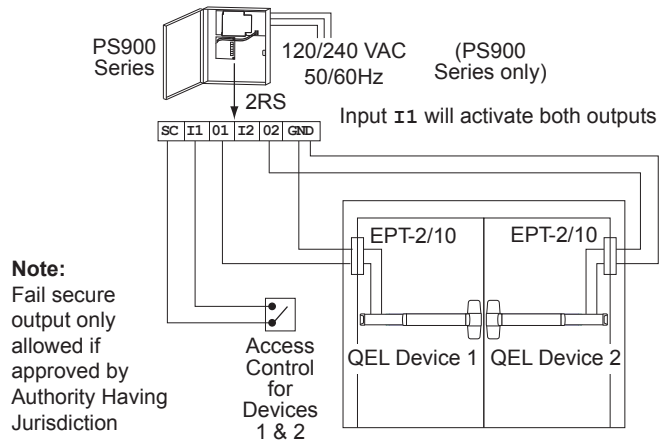

**Note:**  
Fail secure output only allowed if approved by Authority Having Jurisdiction

### Individual Mode - Typical Wiring

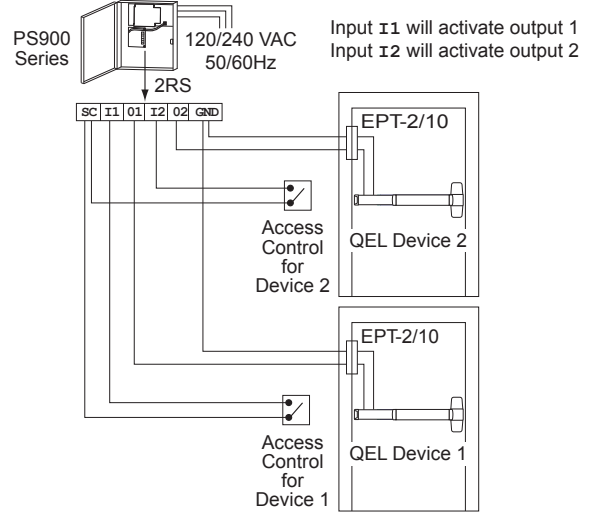

## 15 Check Operation

- A. Activate each input and verify all QEL devices operate properly.
- B. If any device does not operate properly, see step 16 for troubleshooting.

## 16 If Necessary, Troubleshoot Operation (LED is only visible with the mechanism cover removed)

Power at the QEL	QEL Response	Condition/Solution
24VDC	LED - Solid green Latchbolt - retracted	Operation normal, latch retracted immediately
	LED - Solid red after latchbolt attempts to retract multiple times	Latchbolt cannot fully retract mechanically Verify mechanical adjustment (on vertical rod or mortise lock devices if used). Remove and reapply input voltage to reset this condition.* See <i>Check Mechanical Operation</i> on page 8 as needed.**
	LED - Flashing green/red Latchbolt - not retracted	Excessive tamper (while power applied, the pushpad was pulled out at least 3 time) Wait 15 seconds and latchbolt will retract again OR remove and reapply power to clear condition
24VDC low	LED - Flashing green Latchbolt - retracted	Voltage low during latchbolt retraction (latchbolt retracts at reduced force) Wire length is too long, wire gauge is too small or power supply has poor regulation
29VDC or greater	LED- Flashing red Latchbolt - will not retract	Input voltage is too high for proper operation Wrong power supply, power supply defective.
13VDC or lower		Input voltage is too low for proper operation Wrong power supply, power supply defective or not set to the proper output voltage. To set, remove AC power from power supply, change power supply setting from 12 to 24VDC, then reapply AC power and verify proper operation.
0VDC	LED - off Latchbolt - not retracted	No input voltage Problem with the power supply, control switch or wiring
0VDC	LED - off Latchbolt - retracted	No input voltage Mechanical dogging is engaged

\*For information about adjusting exit devices, you can find their installation instructions in the support area at [www.allegion.com/us](http://www.allegion.com/us) or call Technical Services at 1-877-671-7011

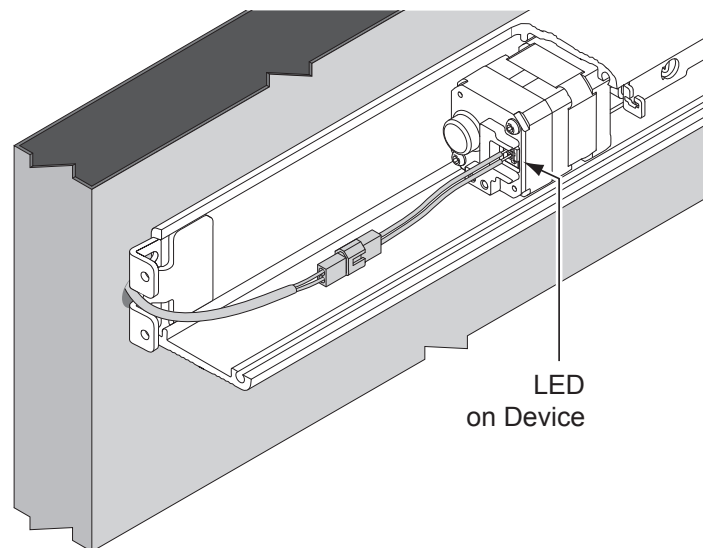

# 17 Check Mechanical Operation

33A/3527A	98/9927	98/9947WDC
33A/3547A	98/9947	98/9957
		98/9975

33/3549A	98/9949
33/3550A-WDC	98/9949WDC
	98/9950WDC

1. Make sure device is not dogged for SD-QEL / HD-QEL.
2. Depress pushbar and make sure latch bolt retracts and extends fully (see Figure 1).
3. If latch bolt does not retract or extend fully, adjustments may be required per the device installation instructions.

1. Make sure device is not dogged for SD-QEL/HD-QEL.
2. Depress pushbar. Door should begin to open with pushbar depressed halfway.
3. Close door. Top latch should be secure. If two point latch, bottom latch should be secure as well.
4. If device does not function as described in steps 2 and 3, adjustments may be required per the device installation instructions.

Any HD Device

1. Fully depress pushbar.
2. Insert hex dogging key and turn clockwise.
3. Release pushbar and verify latchbolt remains retracted.
4. Fully depress pushbar.
5. Insert hex dogging key and turn counter clockwise.
6. Release pushbar and verify latchbolt extends fully.

