



640009-00

25-C, F-25-C, & F-25-WDC-90

FALCON®

Concealed Vertical Rod Exit Device
Dispositivo de salida con varilla vertical oculta
Appareil de sortie de la tige verticale couverte

Installation Instructions
Instrucciones de Instalación
Notice d'installation

#10-24

2" (51 mm)

F-25-WDC-90 Only
Solamente F-25-WDC-90
F-25-WDC-90 Seulement

Fire (F) Latch
Seguro Incendio (F)
Verrou Incendie (F)

Dogging Key
Llave del trinquete
Œillet vissé

Use to lock down pushbar
Utilícela para asegurar hacia abajo la barra de empuje
Utilisé pour verrouiller la barre antipanique

Customer Service Servicio al cliente Service à la clientèle
1-877-671-7011 www.allegion.com/us

© Allegion 2019
Printed in U.S.A.
640009-00 Rev. 03/19-g



If sexbolts are in box, see Sexbolt Preparation on page 7
 Si los pernos macho-hembra se encuentran en la caja, consulte preparación de pernos macho-hembra en la página 7
 Si les colonnettes sont dans la boîte, voir « Préparation de colonnette » à la page 7

1

Prepare Door Cutout
Prepare el Corte de la Puerta
Préparer le Découpage de Porte

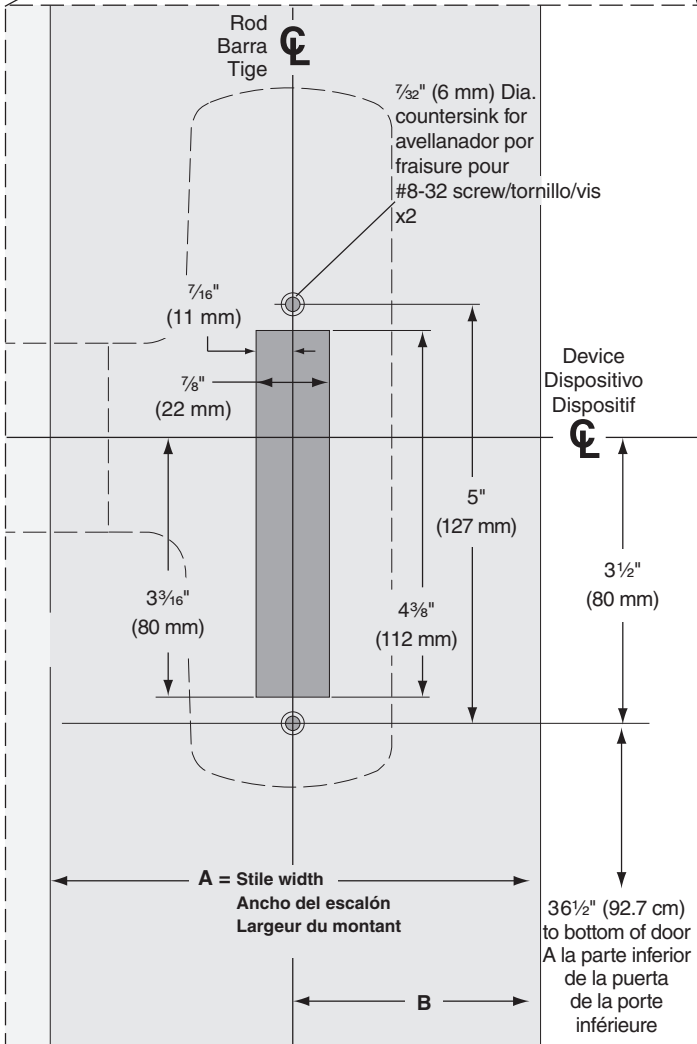
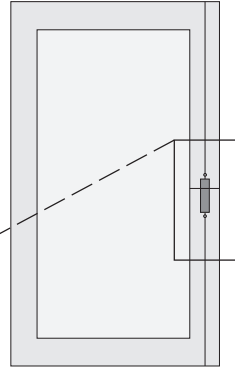
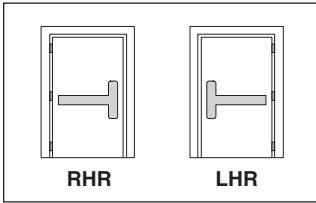

A	B
3 1/2" to 4 1/2"	1 3/4"
4 1/2" or greater	2 3/4"

2

Mark 4 Holes
Marque 4 Orificios
Marquer 4 Orifices

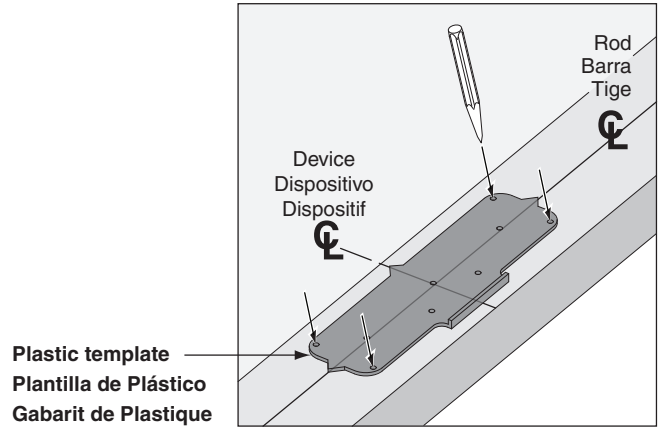

3

If Installing Trim, Go To Trim Instructions
Si instala la Moldura, Vaya a las Instrucciones de Moldura
Si Installation d'une Garniture, voir « Instructions de Garniture »

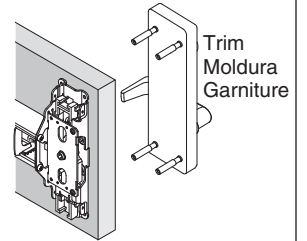

4

Prepare 4 Holes
Prepare 4 Orificios
Préparer 4 Orifices

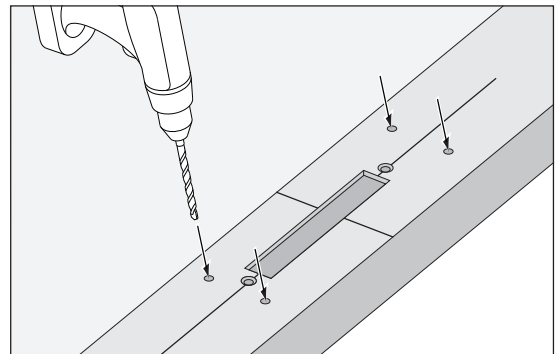

F-25-C

#25

#10-24

--- OR O OU ---

25-C

1/8" (3 mm) X 1" (25 mm)

5

Prepare Top Latch Holes
Prepare los Orificios del Seguro en la Parte Superior
Préparer les Orifices Supérieurs du Verrou

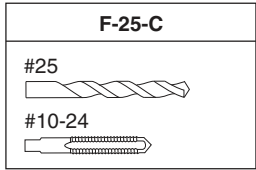
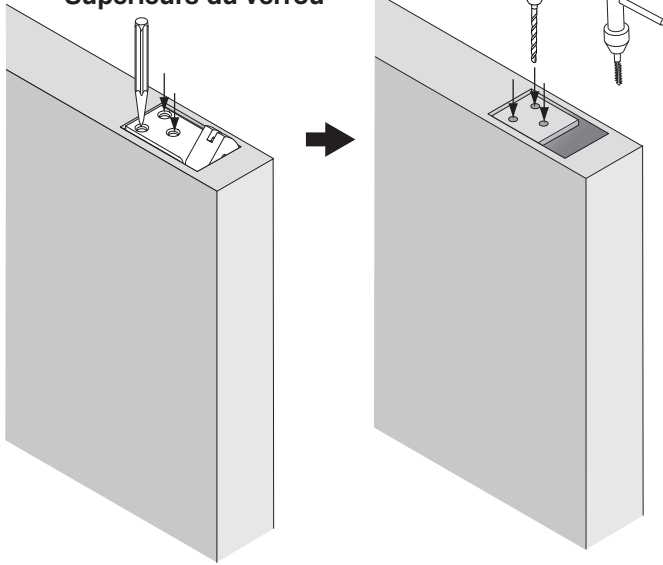

OR
O
OU

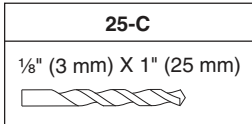
**6**

Prepare Bottom Latch Holes
Prepare los Orificios del Seguro en la Parte Inferior
Préparer les Orifices Inférieurs du Verrou
 Skip for LBR
 Sáltese para LBR
 Passer pour LBR

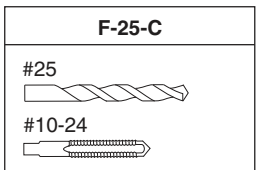
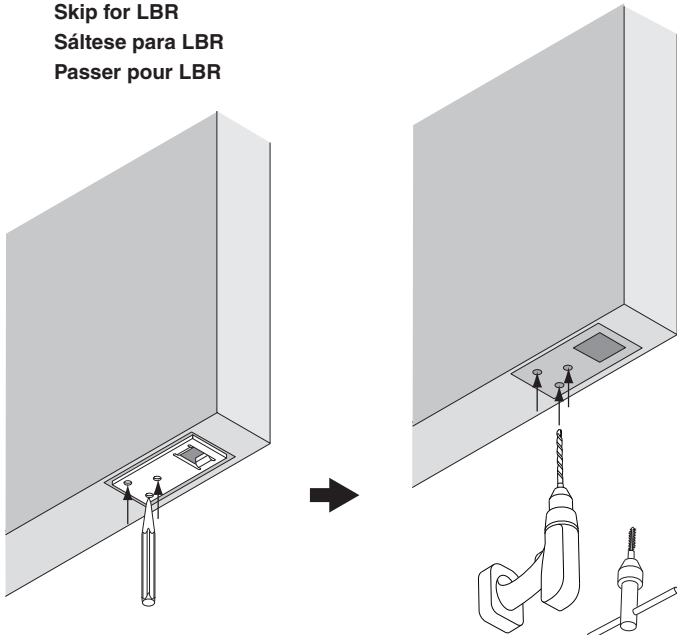

OR
O
OU

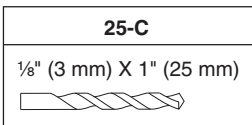
**7**

Prepare Hole for Release Bracket
Prepare Orificio para la Ménsula de Liberación
Préparer L'orifice pour le Support de Dégagement

A	B
1/2" (13 mm)	5/8" (16 mm)
5/8" (16 mm)	3/4" (19 mm)
3/4" (19 mm)	7/8" (22 mm)

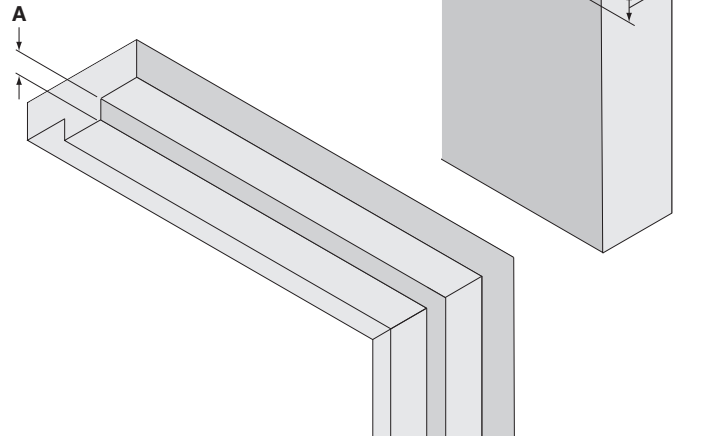
**8**

Install Top Strike & Release Bracket
Instale el Cerrojo en la Parte Superior y Libere la Ménsula
Installer la Gâche Supérieure et le Support de Dégagement

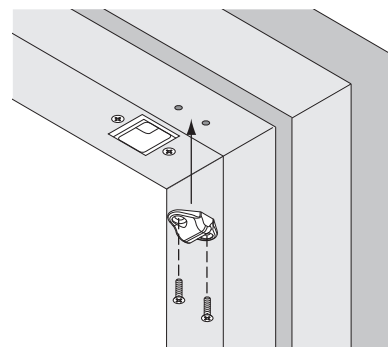
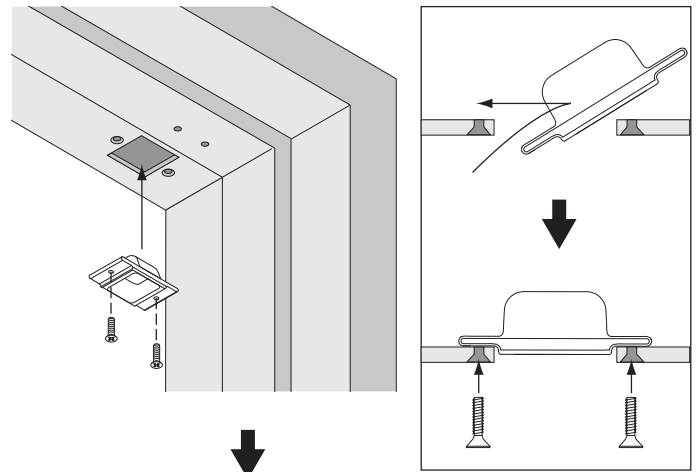

See "Door Frame Preparation" on Page 7

Consultar "Preparación del Marco de la Puerta" en la Página 7

Voir « Préparation du Cadre de porte » à la Page 7

9 Prepare Top Rod Length
Preparar la Longitud de la Barra en la Parte Superior
Préparer la Longueur de la Tige Supérieure

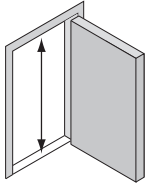
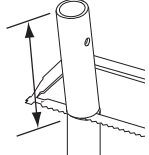
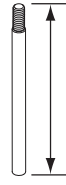
Height Altura Hauteur	*Rod Cut Required *La barra Requiere Corte *Coupe de Tige Nécessaire	Extension Required Extensión que se Requiere Longueur Nécessaire
		
6' 8"	4"	—
7' 0"	—	—
7' 2"	10"	1'
7' 6"	6"	1'
7' 10"	2"	1'
8' 0"	—	1'
8' 6"	6"	2'
8' 10"	2"	2'
9' 0"	—	2'
9' 6"	6"	3'
9' 10"	2"	3'
10' 0"	—	3'

*Do not cut threaded end of top rod
*No Cortar el Extremo Roscado de la Barra Superior
*Ne pas Couper L'embout Fileté de la Tige Supérieure

10 Drill New Hole, if Necessary
Perforar un Orificio Nuevo, si es Necesario
Percer un Nouvel Orifice si Nécessaire

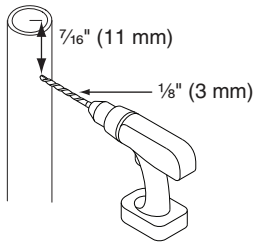

11 Attach Top Rod to Latch
Fijar la Barra Superior al Seguro
Fixer la Tige Supérieure au Verrou

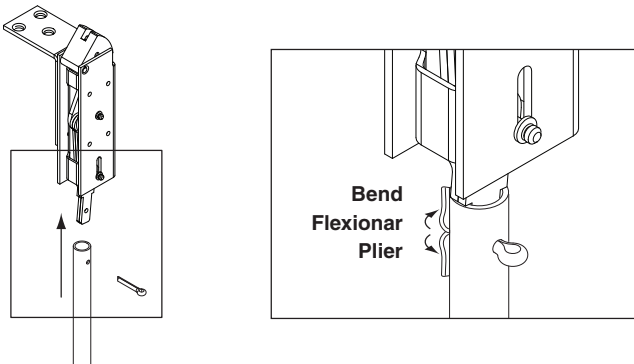

12 Assemble Rods & Latches
Ensamble barras y seguros
Assembler les tiges et verrous

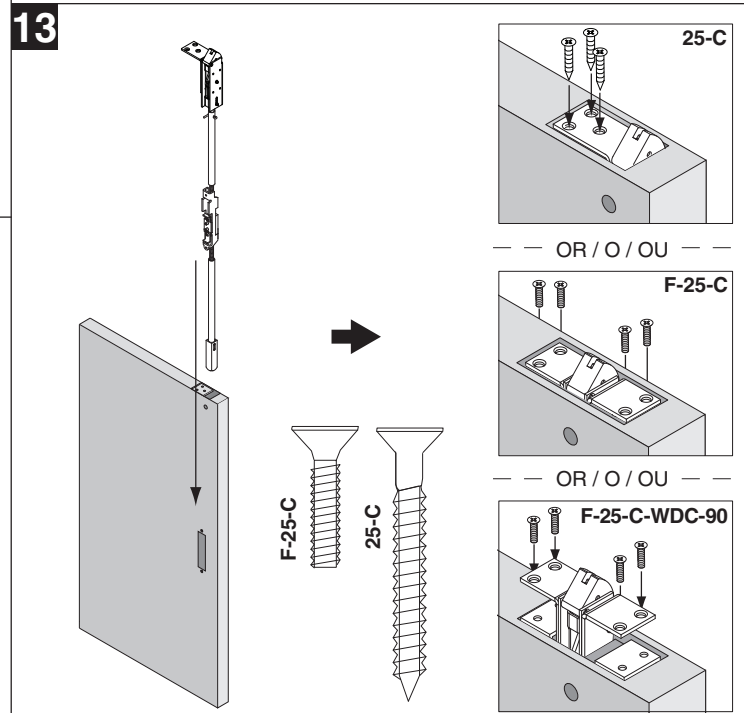
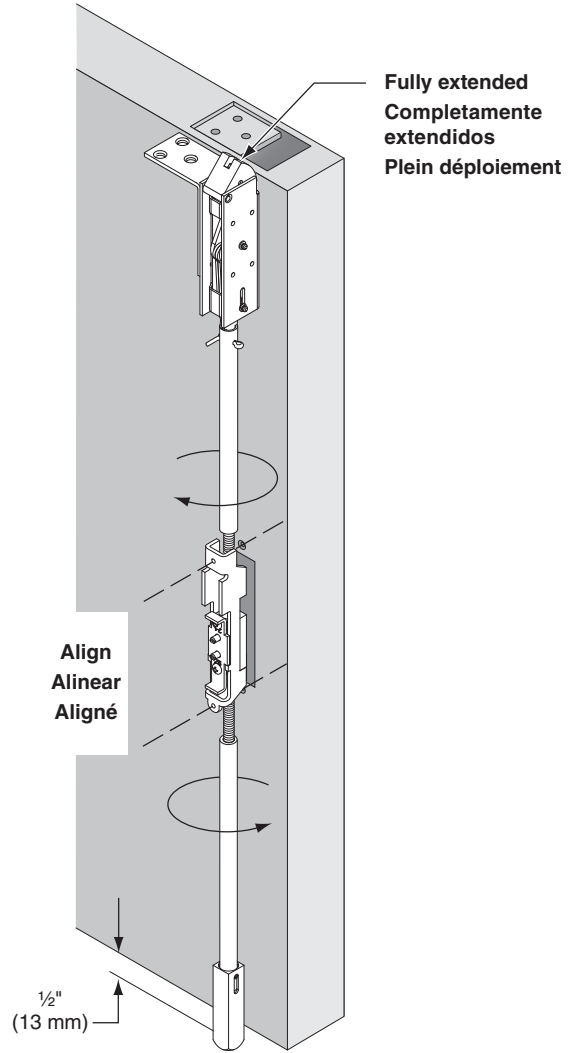

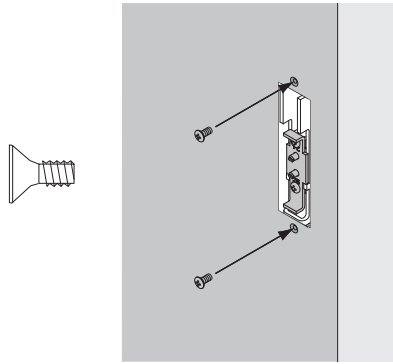
14**17**

Attach Door to Frame
Fijar la Puerta al Marco
Fixer la Porte au Cadre

18

Adjust Center Slide with Latch Fully Extended
Ajustar el Cerrojo Central con el Seguro Extendido Totalmente
Ajuster le Coulisseau Central en Déployant Complètement le Verrou

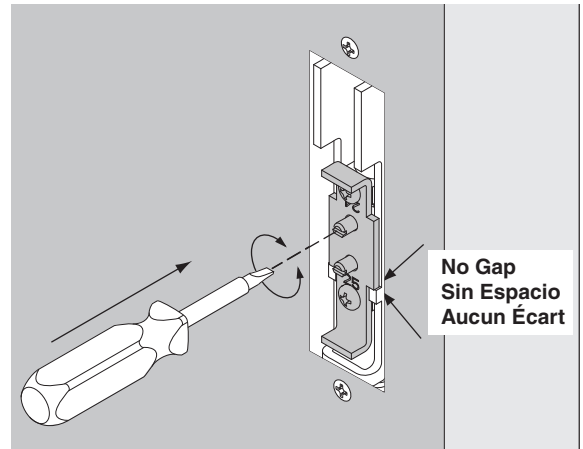
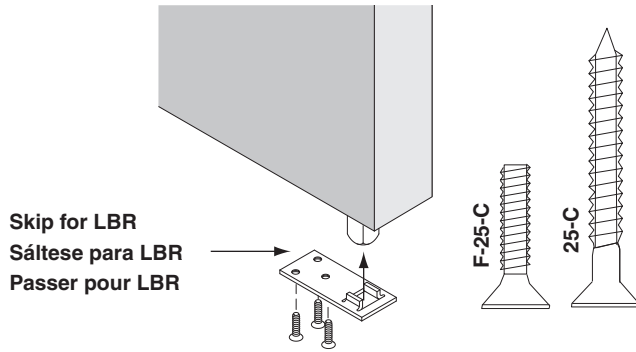
**15****16**

Grout Strike Into Floor
Aplique mezcla para juntas para colocar la cerradura en el piso
Encavure du plancher pour gâche

Skip for LBR
 Sáltese para LBR
 Passer pour LBR

See "Bottom Strike Preparation" on page 8
 Consulte "Preparación de Cerrojo en la Parte Inferior de la Puerta" en la Página 8
 Voir « Préparation de la Gâche de Porte » à la Page 8

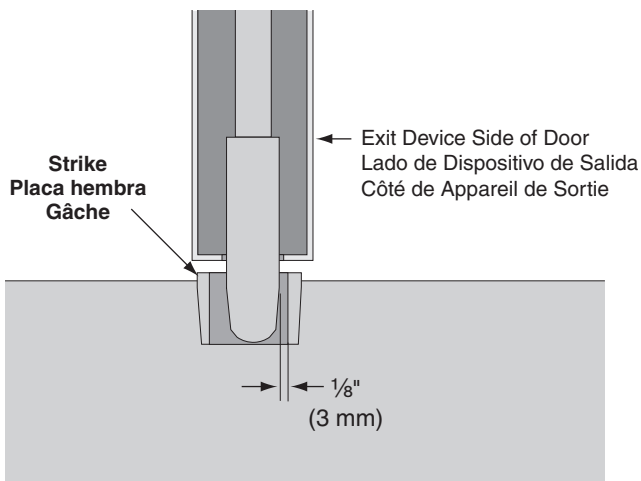
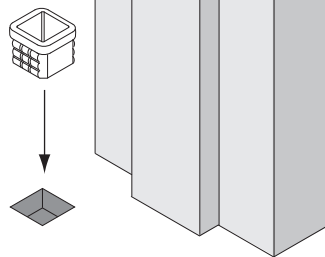
**19**

Verify Latch Retraction
Verificar la retracción del seguro
Vérifier la rétraction du verrou

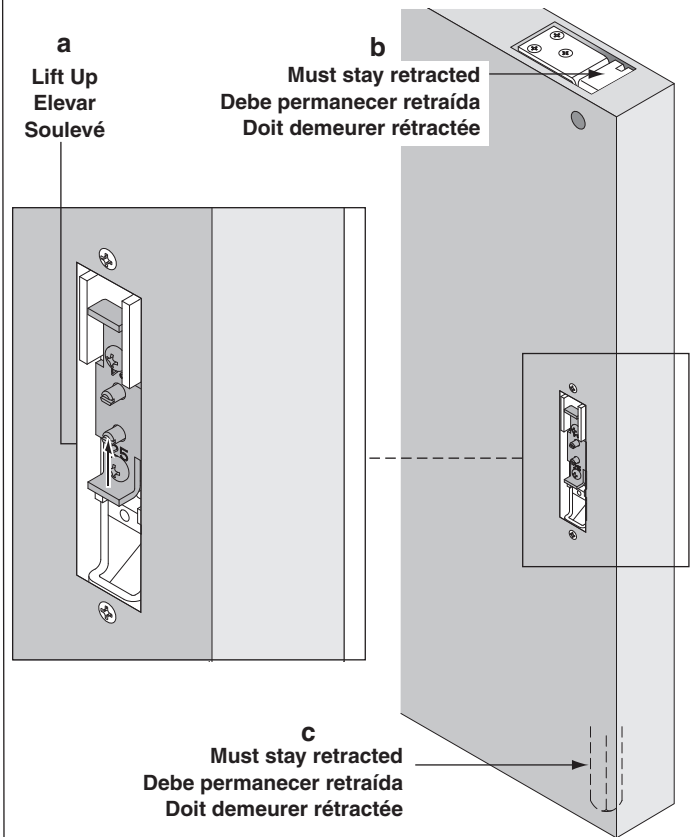

20 Verify full latch extension
 Verificar la Extensión Total del Seguro
 Vérifier le Déploiement Complet du Verrou

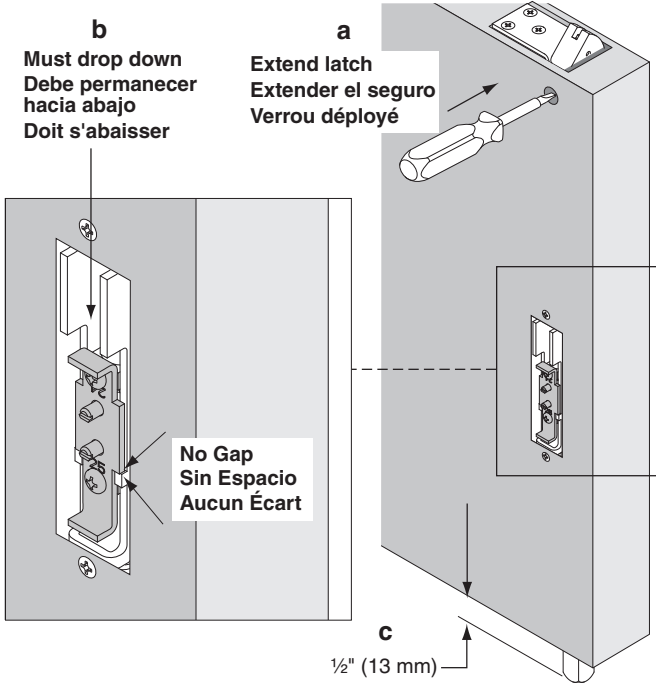

21 If Necessary, Cut Device
 Si Necesario, Corte la Aparato
 Si Nécessaire, Couper le l'Appareil

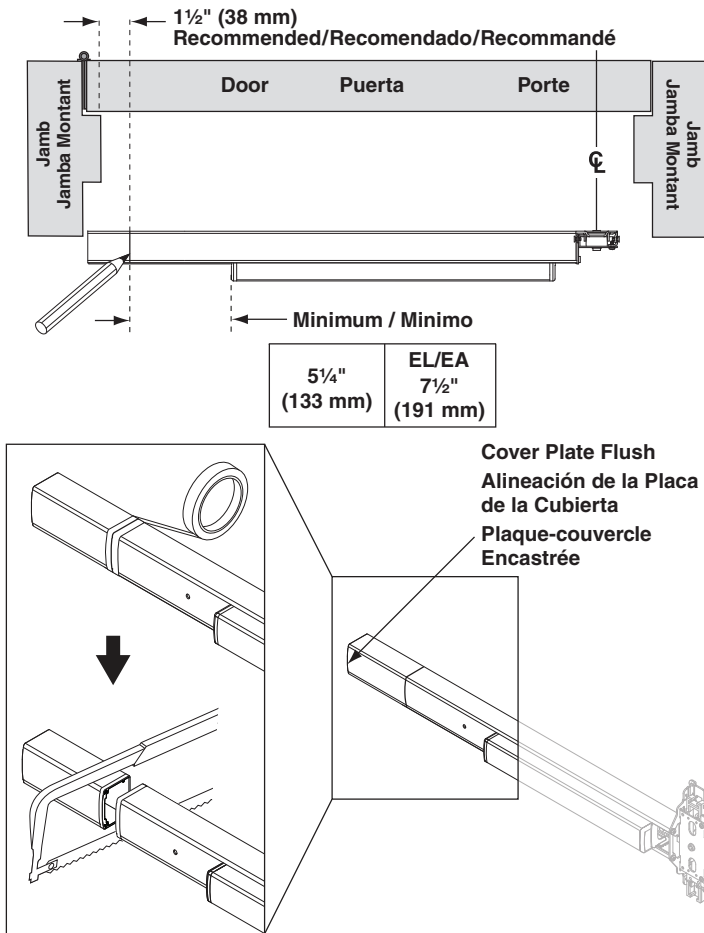

22 If Necessary, Reverse Handing
 Si es Necesario, Invierta el Manejolf
 Inverser L'assemblage si Nécessaire

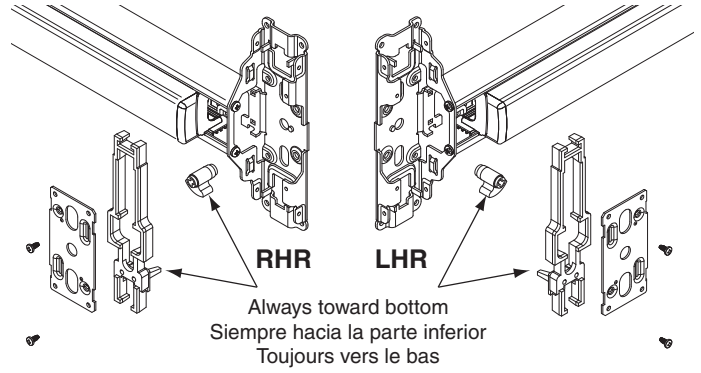

23

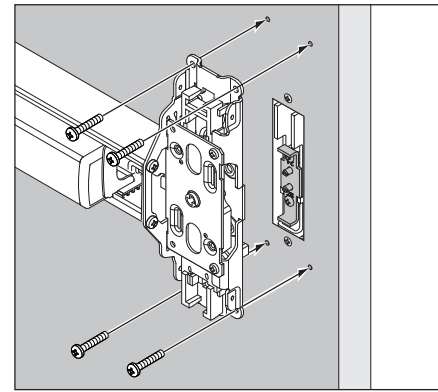

Thru-bolting Trim
Moldura apernada
Vissage transversal de la garniture

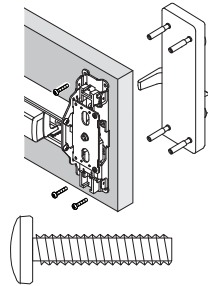

Surface Mount
Montaje en la superficie
Montage en surface

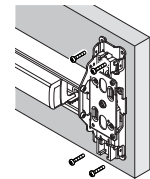

F-25-C

25-C

24 If Necessary, Adjust per Steps 19 & 20
 Si es Necesario, Ajuste Conforme a los Pasos 19 y 20
 Ajuster Selon les Étape 19 et 20 si Nécessaire

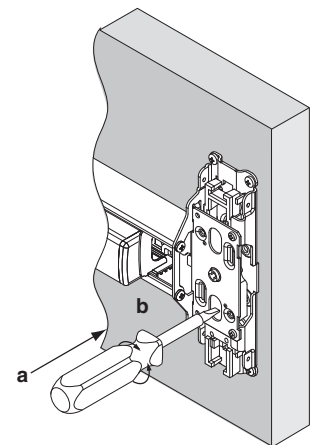

25

Mark and Prepare 2 Holes
Marcar y Preparar 2 Orificios
Marquer et Préparer 2 Orifices

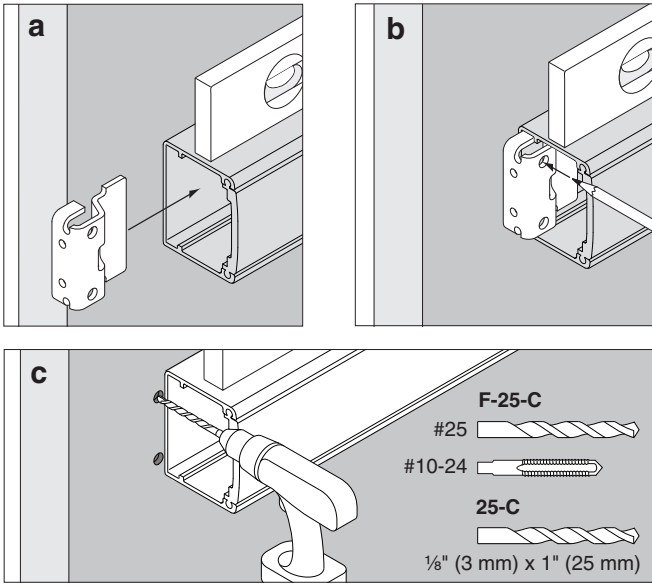

26

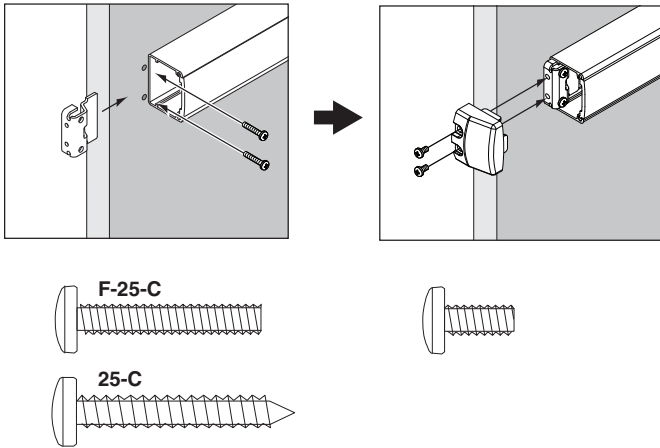

27

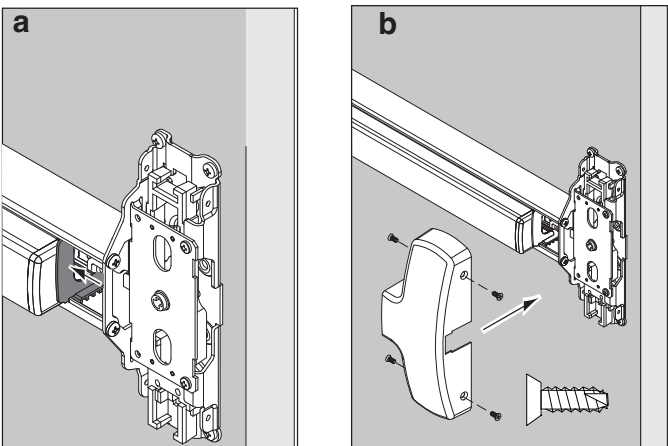

Sexbolt Perno macho-hembra Colonnette
Preparation Préparation Préparation



If sexbolts are in box, during steps 4 and 26 prepare holes and install them as shown below.

Si los pernos macho-hembra se encuentran en la caja durante los pasos 4 y 26 prepare los orificios e instáloselos como se muestra a continuación.

Si les colonnettes sont dans la boîte lors des étapes 4 et 26, préparer les orifices et installez-les comme illustré ci-dessous.

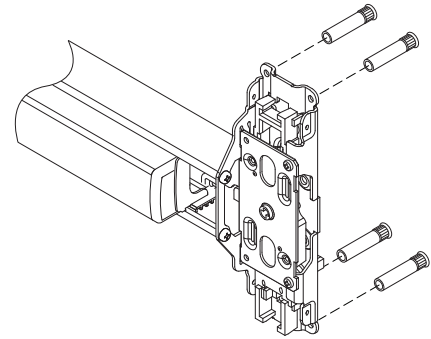
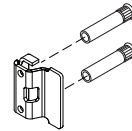
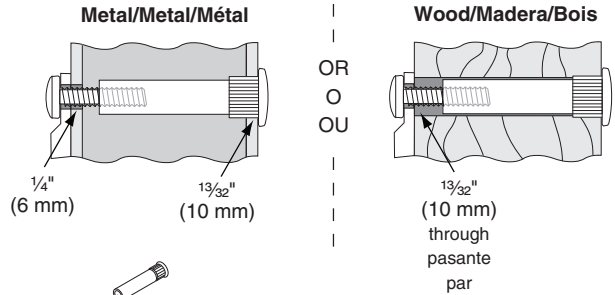

Door Frame Preparation
Preparación del Marco de la Puerta
Préparation du Cadre de Porte

Do not use slots for position. Drill as directed here.
 No utilice ranuras para posicionar. Perfore como se indica aquí.
 Les fentes ne doivent pas être utilisées comme position. Percez comme indiqué ici.

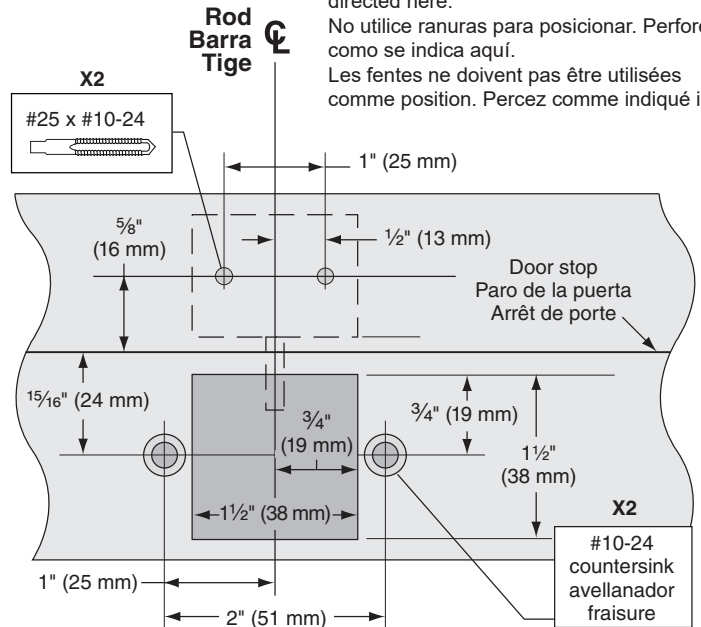

Top Latch (Fire)
Seguro en la parte Superior (Incendio)
Verrou Supérieur (Incendie)

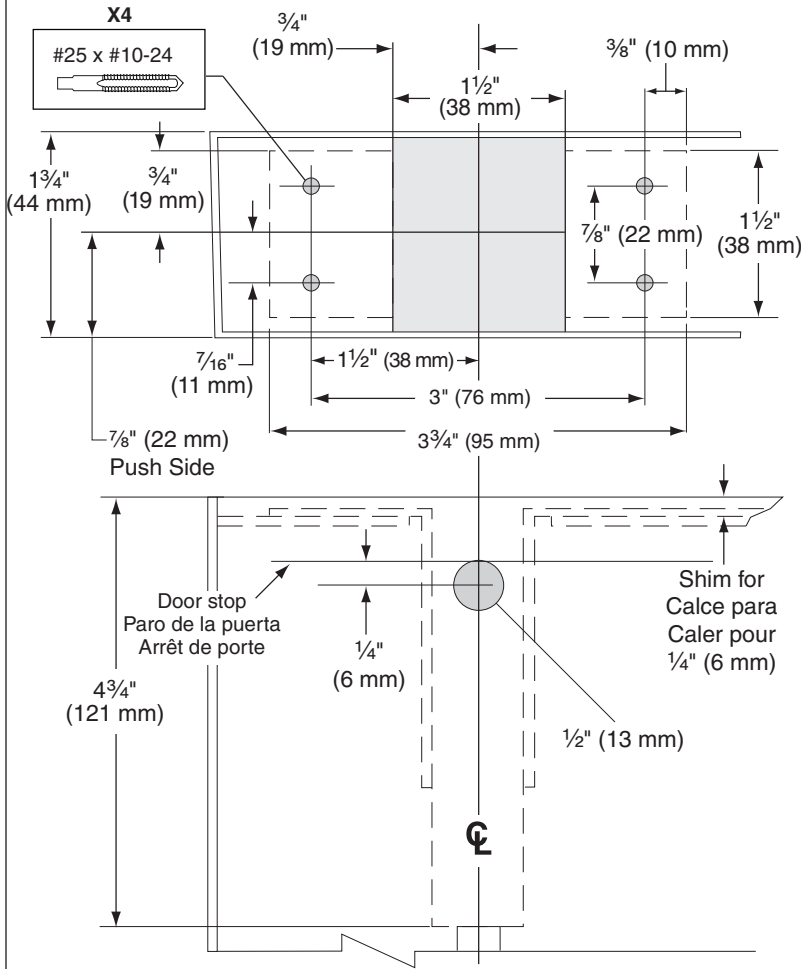

Top Latch (Panic)
Seguro en la parte Superior (Pánico)
Verrou Supérieur (Panique)

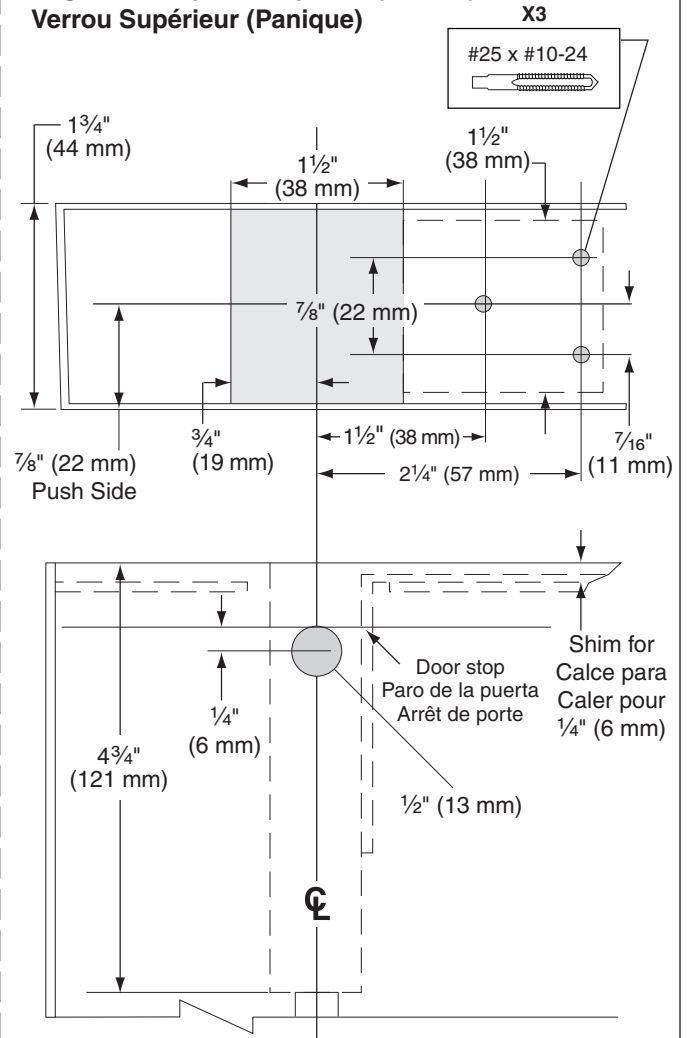

Bottom Bolt Guide
Guía del perno inferior
Guide inférieur du boulon

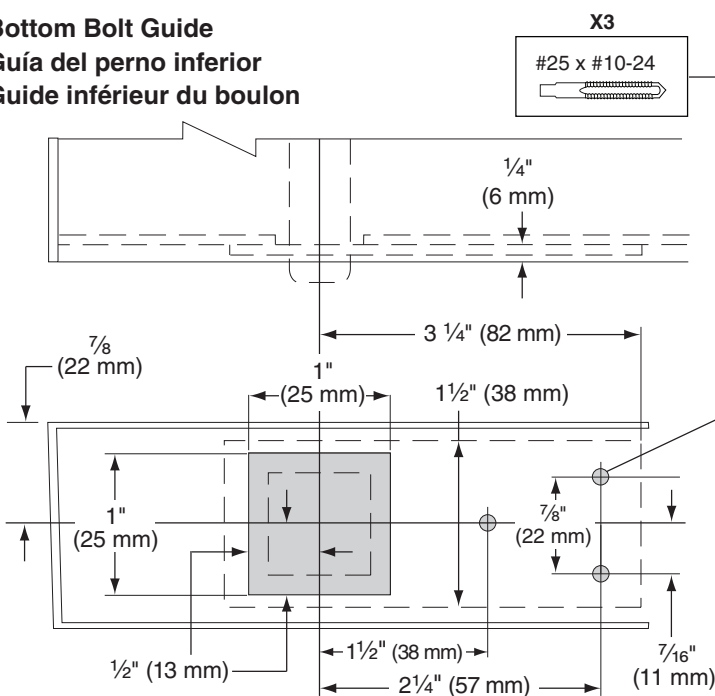

Bottom Strike Floor Cavity
Cavidad del suelo del cerrojo inferior
Encoche de plancher inférieure pour gâche

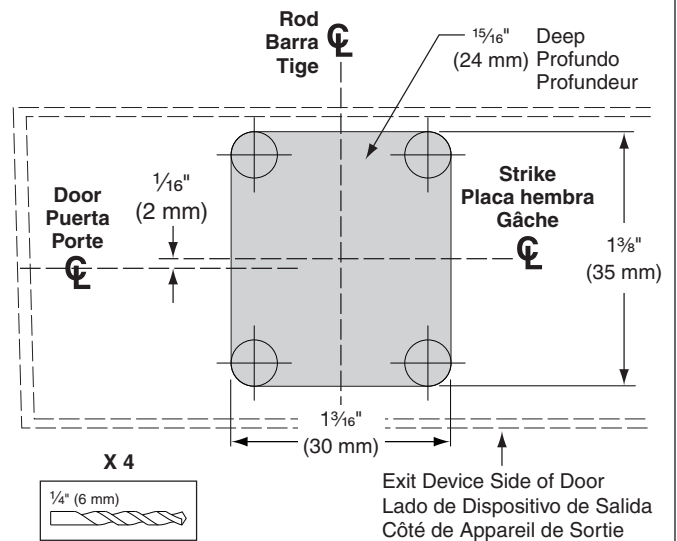



941367-00

MEL 24/25 Series

FALCON®

Motorized Electric Latch Retraction

Installation Instructions



These instructions are for MEL conversion kits or MEL devices with preinstalled motors.

Parts

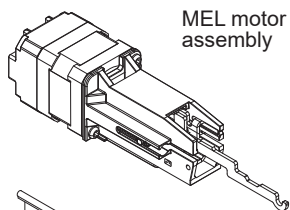

MEL motor assembly

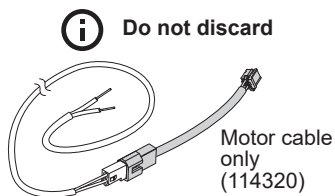

Do not discard

Motor cable only (114320)

MEL 6' cable with motor cable (47269206)

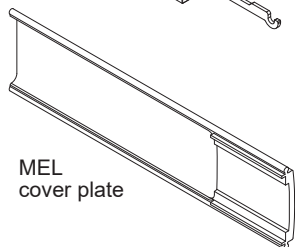

MEL cover plate

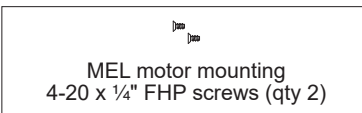

MEL motor mounting 4-20 x 1/4" FHP screws (qty 2)

Allegion Connect accessories available to order

106198 MEL-CON adapter cable with 8-pin connector

040069 MEL motor cable + MEL-CON adapter cable with 8-pin connector



If MEL is preinstalled in the device:

- A. Follow original device instruction up to the point where this end mounting bracket step has been completed.

Mark and Prepare 2 Holes

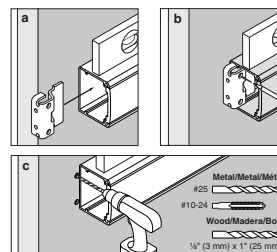

- B. Complete MEL wiring per steps 15-21 of this instruction.
- C. Return to original device instruction at point you left off, and complete installation.



If installing the MEL conversion kit, follow the instruction steps as written.

1 Remove end cap

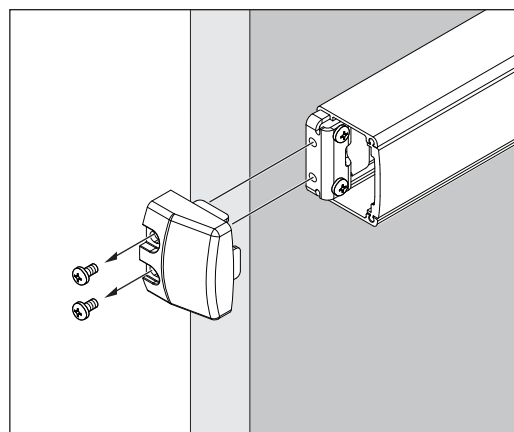

2 Remove device end mounting bracket from door

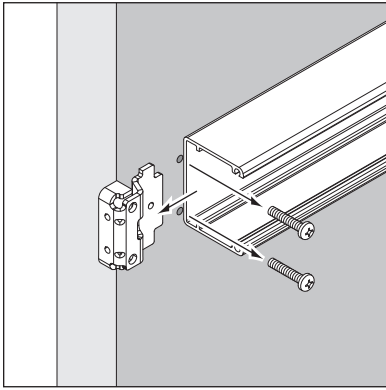

3 Slide back, remove and discard old cover plate

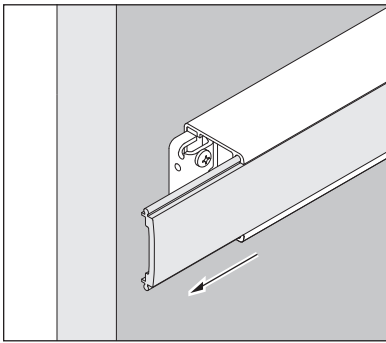

4 Remove center case cover and device from door

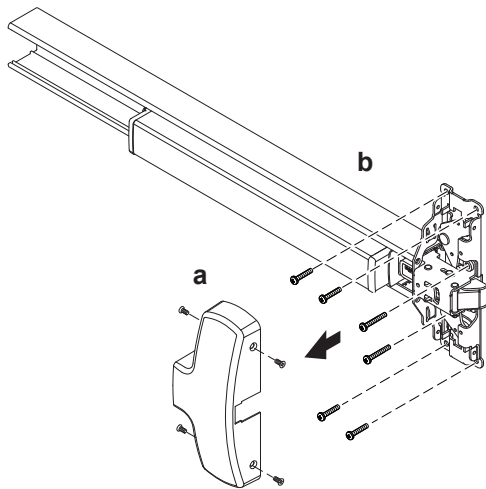

5 With device laying on a table or bench, remove the 2 screws that connect mechanism case to center case

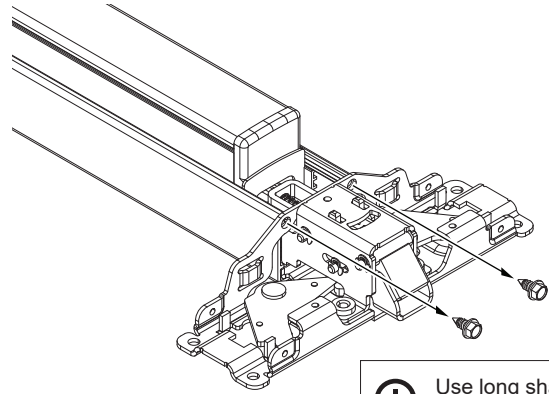

i Use long shank screwdriver.

6 Unhook baseplate from center case

- a. Slide back mechanism case about 2" to access hooking parts.
- b. Push bar guides will come loose and will need to be reinstalled later.
- c. Unhook baseplate from center case.

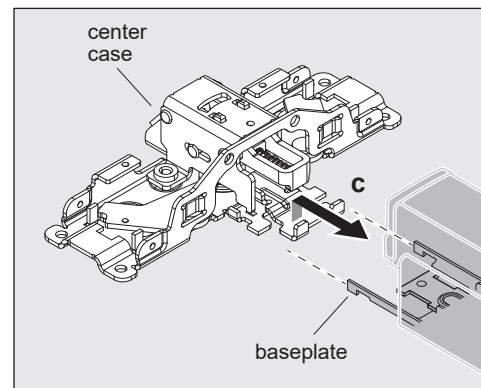
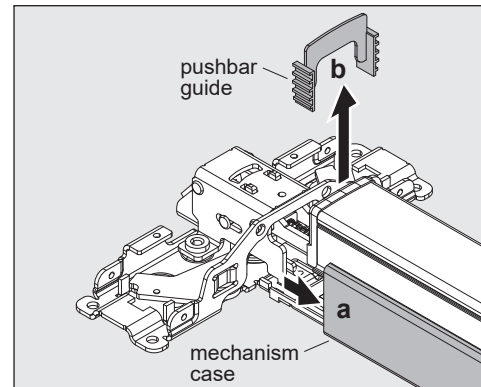

7 Slide baseplate out of mechanism case

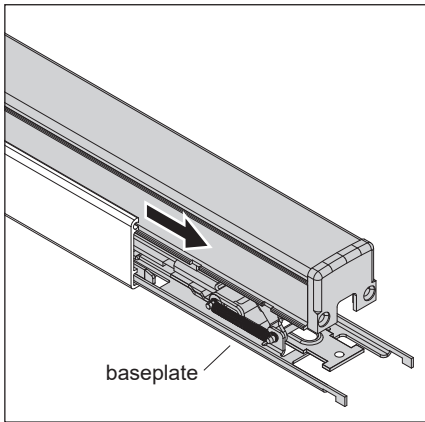

8 Remove any existing dogging assembly

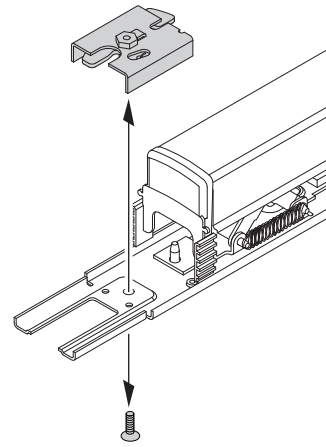

9 Secure motor assembly

- a. Turn baseplate assembly upside down so pushpad is resting on a flat surface and motor mounting location is on the left.

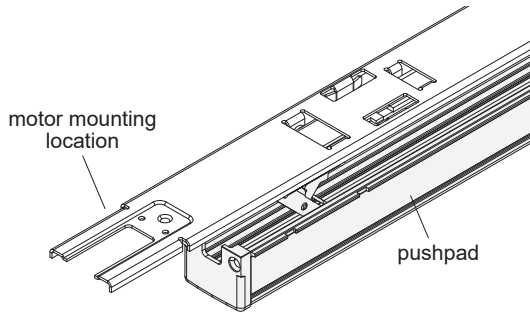

- b. Place motor in left hand with LED status sticker facing toward you. Gently extend silver hook arm outward (about 1/2") until you meet some resistance, then hold.

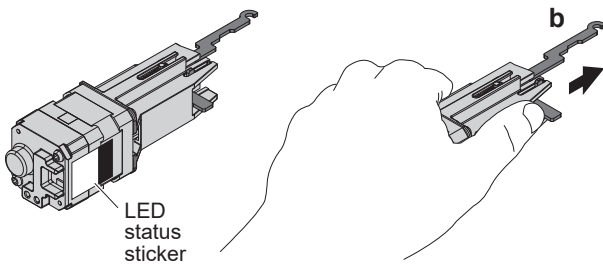

- c. While tilting baseplate assembly away from you slightly, move extended hook arm into position under baseplate. A post will be hanging down from baseplate; the hook arm should sit on the near side of that post. Rotate the motor assembly to hook the arm over the baseplate axle pin that is closest to the baseplate. Do not pull out on motor at this step.

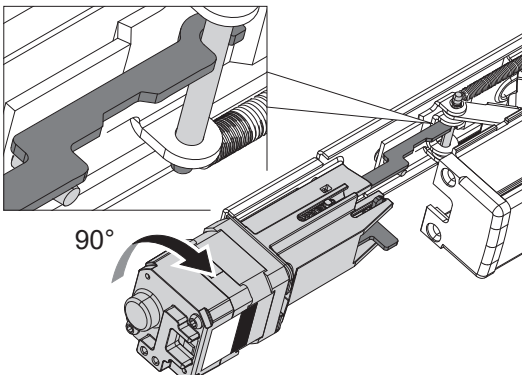
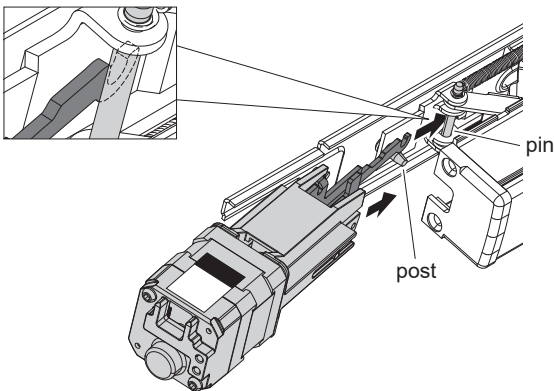

- d. Set motor on flat surface.

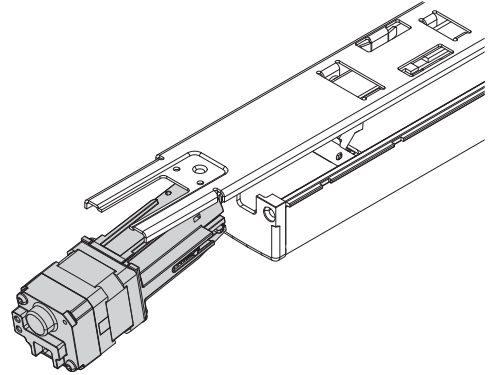

- e. Push down firmly on baseplate so it bottoms out against push pad.
f. While depressing baseplate, lift up motor assembly and guide it along elongated baseplate slot until motor lip slips over baseplate.

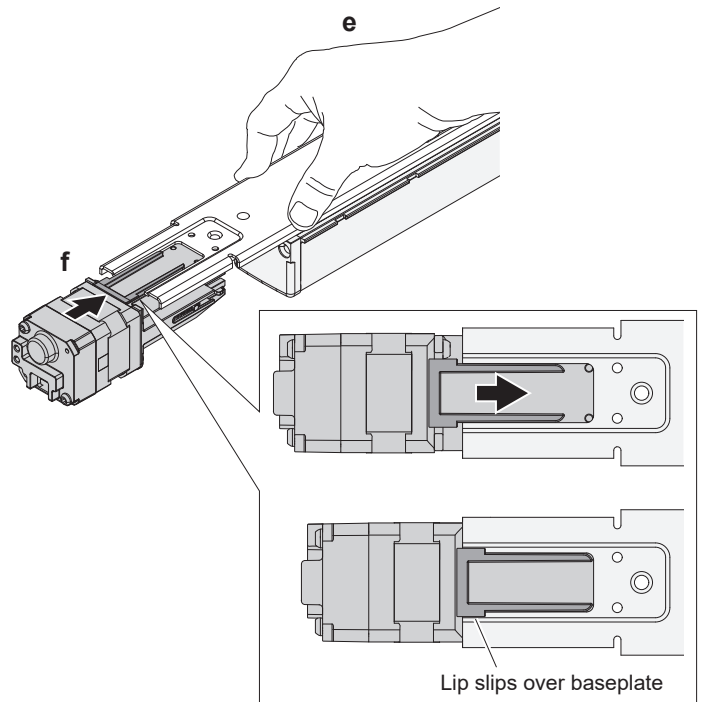

- g. Release baseplate. Secure motor assembly with 2 small self-tapping screws (provided).

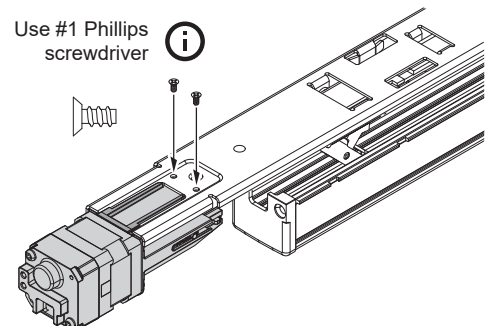

- h. Turn baseplate and motor assembly right side up.

10 Slide mechanism case onto baseplate

Insert pushbar guide ahead of motor assembly and hold in place (a) while sliding mechanism case onto baseplate (b)

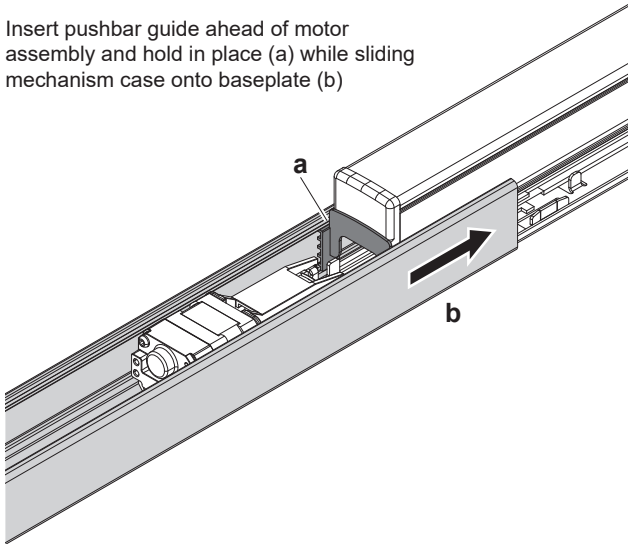

13 Reattach mechanism case to center case

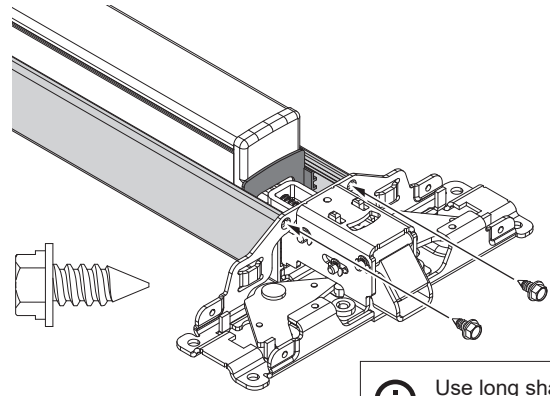

i Use long shank screwdriver.

11 Reconnect center case to baseplate via hooking parts

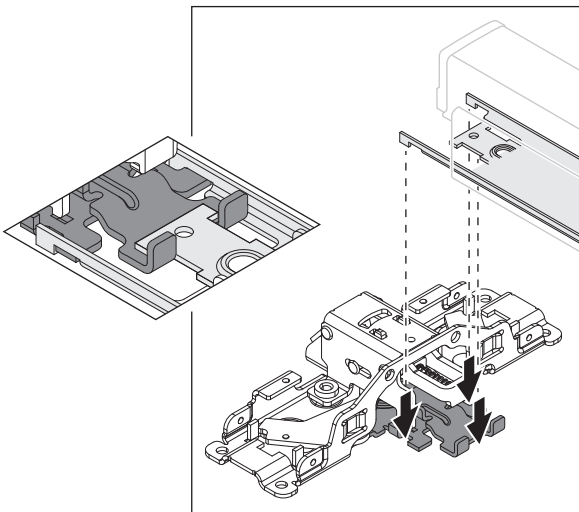

14 Reattach device to door

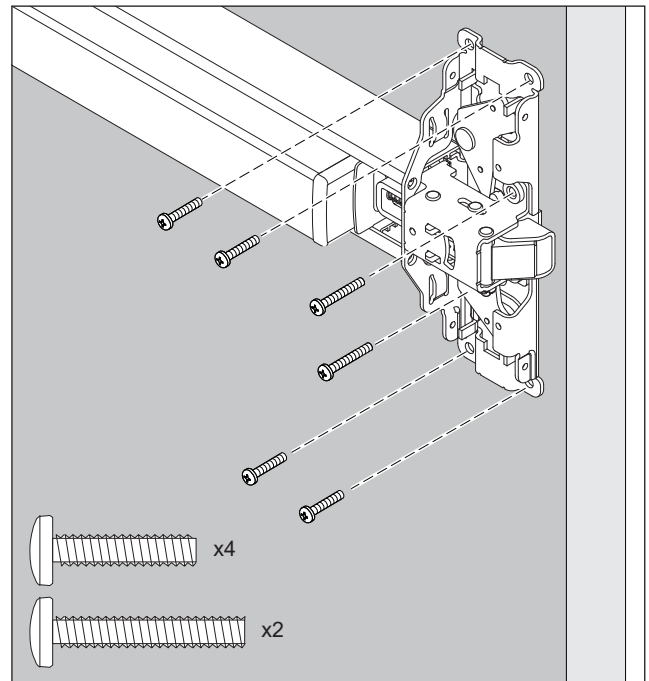

12 Insert remaining pushbar guide (nearest the center case) and slide mechanism case against center case

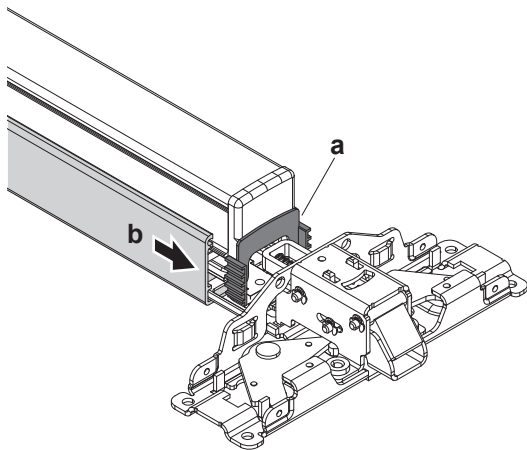

15 Complete wiring

i If not wiring at this time, **DO NOT DISCARD CABLE!**
 After installing device or conversion kit, if there is room, store the cable inside the mechanism case until the electrical wiring occurs. Otherwise, store the cable in a designated location.

- Drill wire access hole.
- Route furnished 6' MEL two-piece cable thru device end mounting bracket to connect MEL device to power transfer wires.
- Plug cable connector into MEL motor.
- Reinstall end mounting bracket.
- Refer to table below to route proper gauge wires (from electric hinge, EPT, or door loop) to PS900-Series power supply.

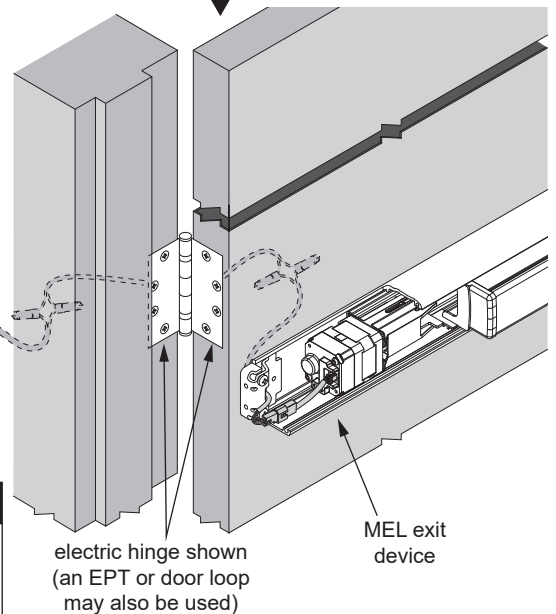
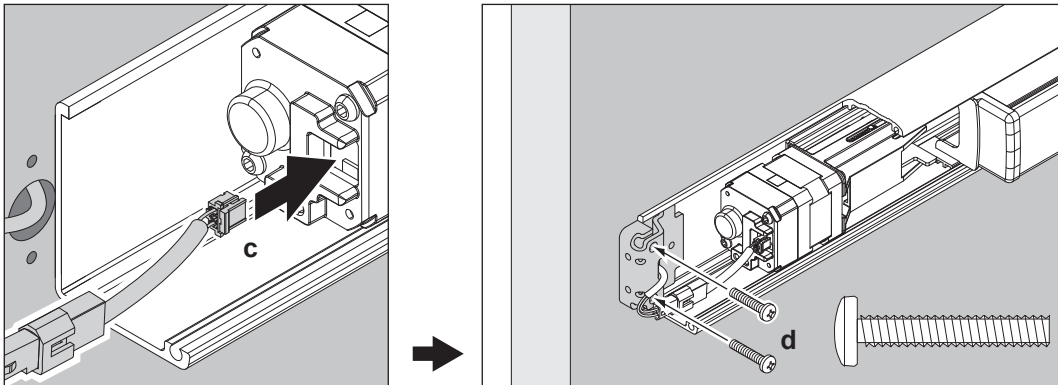
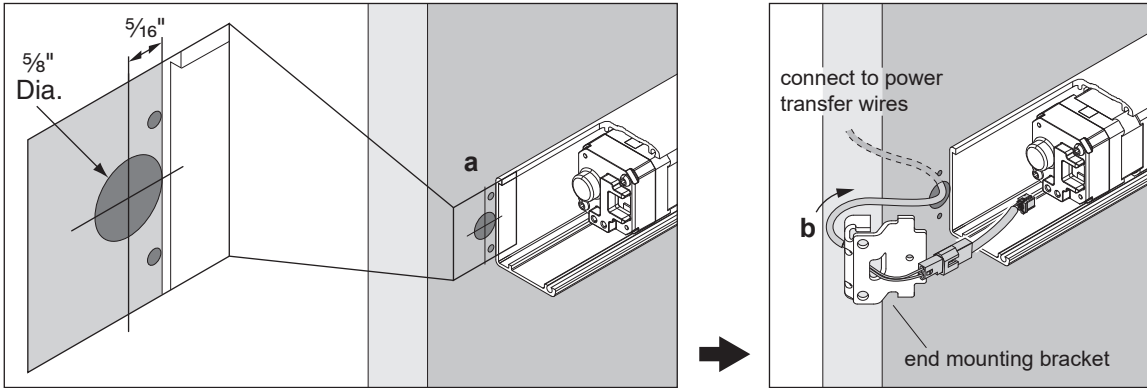

PS900-Series power supply with 900-Series option board(s) installed

MEL device used with EPT, Electric Hinge, or Door Loop	
Distance (one way)	Wire Gauge
200'	18AWG
320'	16AWG
500'	14AWG
800'	12AWG

MEL Electrical Load

Voltage: 24 VDC
 Current: 1.0 A inrush (0.5 sec)
 0.14 A holding

i Power wires to MEL are not polarized.

⚠ WARNING

To avoid risk of electric shock, turn off AC power to power supply before installing or wiring option board.

16 Confirm equipment compatibility

MEL is compatible with the following equipment (refer to individual instructions as needed):

- PS900-Series power supplies - PS902, PS904, PS906, PS914
- 900-Series option boards - 900-2RS, 900-4R, 900-4RL

17 Install 900-2RS, 4R, or 4RL option board(s) into power supply

a Review Available 900 series Option Board Mounting Locations (Gray)

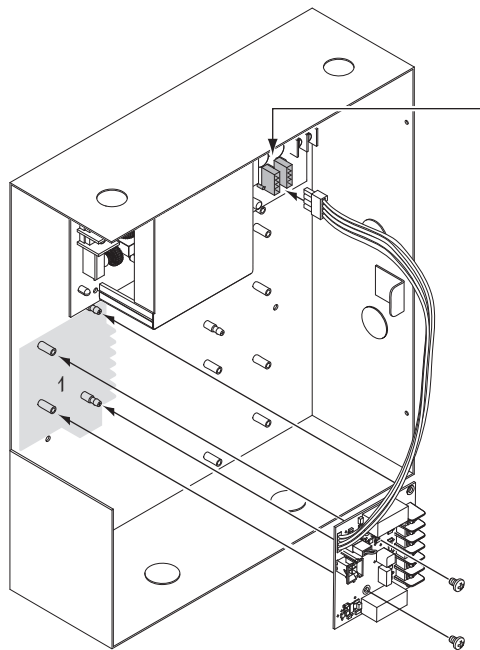
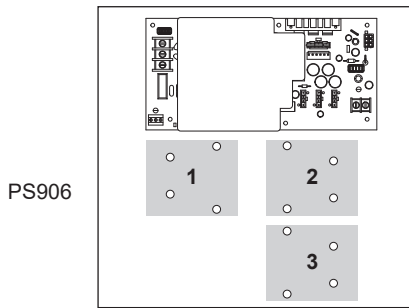
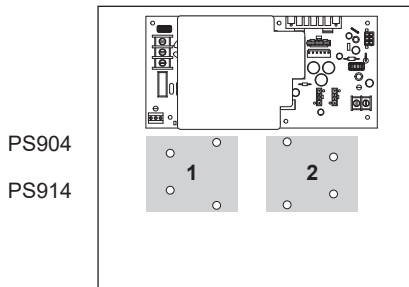
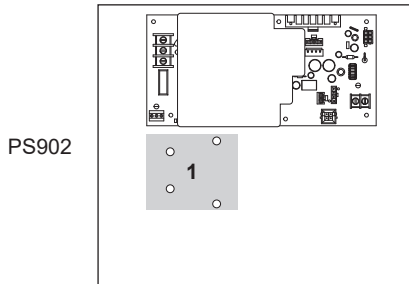

b Plug Option Board Cable into any Available Option Connector

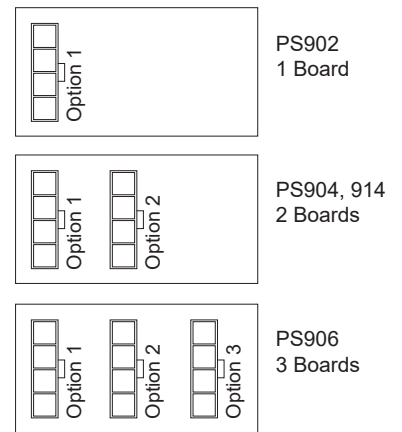

c Secure Board(s) with Screws

⚠ WARNING

Fire alarm (FA) option board required if MEL is installed in fire exit hardware.

- Notes:**
1. 24 VDC output setting required when MEL device connected.
 2. If installing board in location 2 or 3, rotate board 180°.
 3. Latchbolt retraction of (2) sequenced MEL devices requires more than 1 second to complete.
 4. When powering multiple components, verify that the amperage requirements of all components combined does not exceed the power supply output rating.

18 Connect input and output wires to option board (2RS shown)

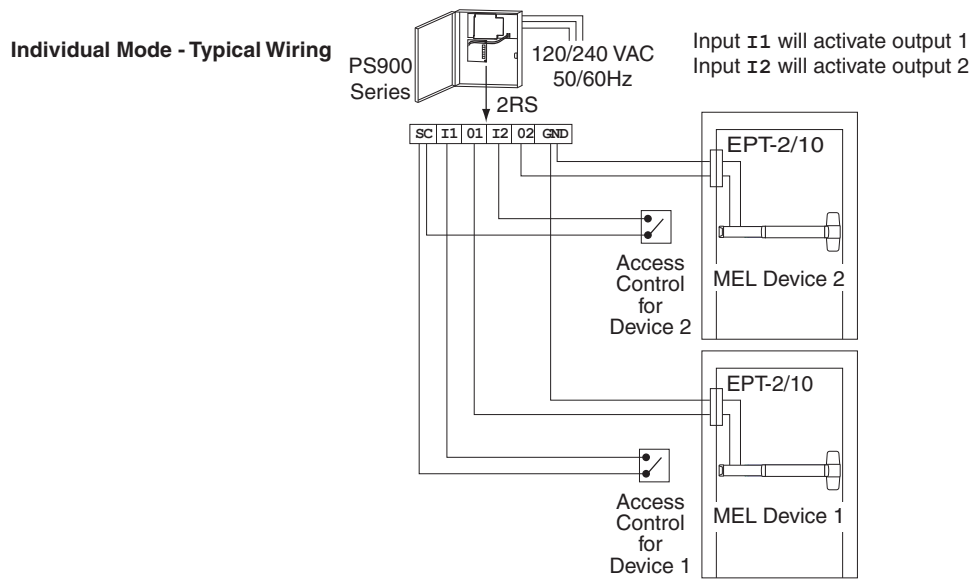
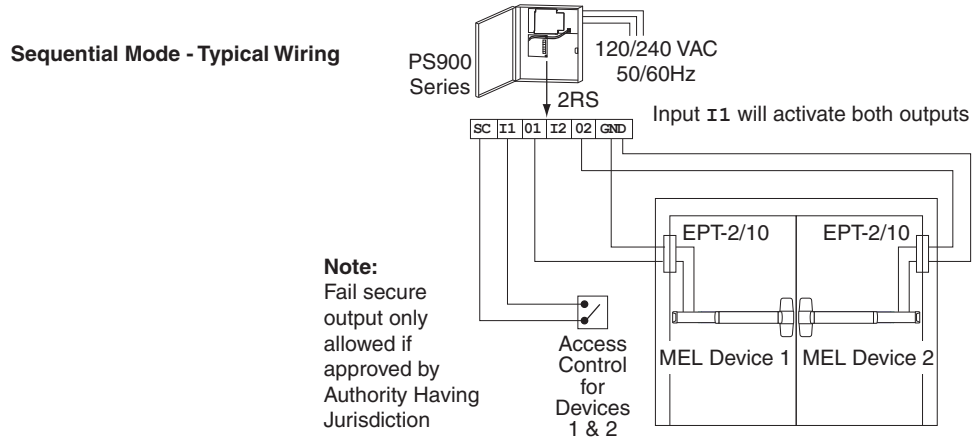

19 Check operation

- a. Activate each input and verify all MEL devices operate properly.
- b. If any device does not operate properly, see next page for troubleshooting.

20 If necessary, troubleshoot operation (LED is only visible with the mechanism case removed)

Power at the MEL	MEL Response	Condition/Solution
24 VDC	LED - solid green Latchbolt - retracted	Operation normal, latch retracted immediately
	LED - solid red after latchbolt attempts to retract multiple times	Latchbolt cannot fully retract mechanically Remove power. Depress pushbar and make sure latchbolt retracts and extends fully. If necessary, disconnect any vertical rods or mortise lock from device center case, and reapply power. If motor holds, mechanical adjustments may be required per the device instructions.*
	LED - flashing green/red Latchbolt - not retracted	Excessive tamper (while power applied, the pushpad was pulled out at least 3 times) Wait 15 seconds and latchbolt will retract again OR remove and reapply power to clear condition.
24 VDC low	LED - flashing green Latchbolt - retracted	Voltage low during latchbolt retraction (latchbolt retracts at reduced force) Wire length is too long, wire gauge is too small, or power supply has poor regulation.
29 VDC or greater		Input voltage is too high for proper operation Wrong power supply, power supply defective.
13 VDC or lower	LED- flashing red Latchbolt - will not retract	Input voltage is too low for proper operation Wrong power supply, power supply defective or not set to the proper output voltage. To set, remove AC power from power supply, change power supply setting from 12 to 24 VDC, then reapply AC power and verify proper operation.
0 VDC	LED - off Latchbolt - not retracted	No input voltage Problem with the power supply, control switch, or wiring.

**For information about adjusting exit devices, you can find their installation instructions in the support area at www.allegion.com/us or call Technical Services at 1-877-671-7011*

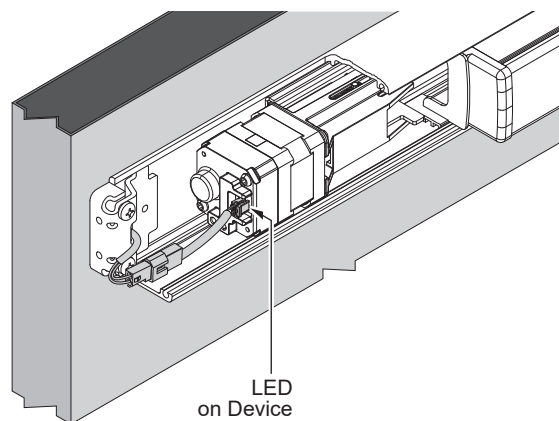

21 Install MEL cover plate

i Do **not** cut from recessed end of cover plate

i Install this end first

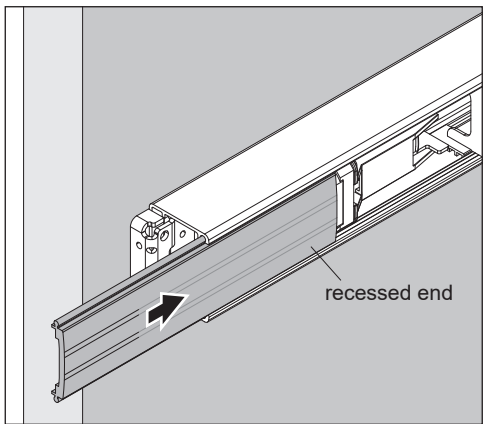
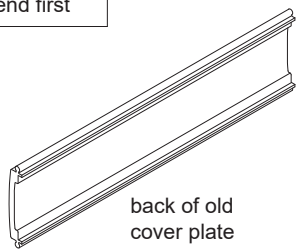
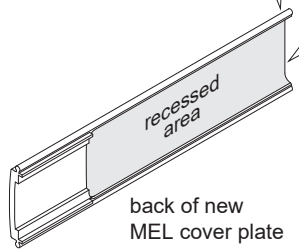

22 Reinstall end cap

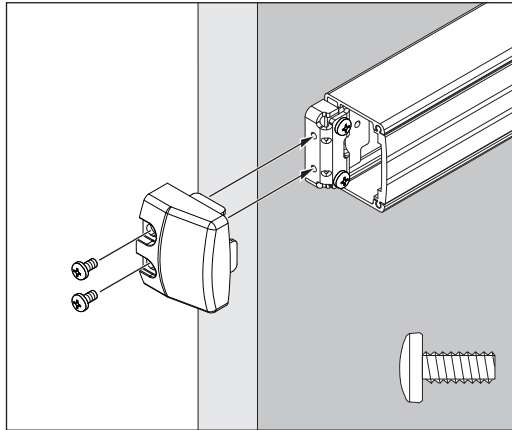

23 Reinstall center case cover

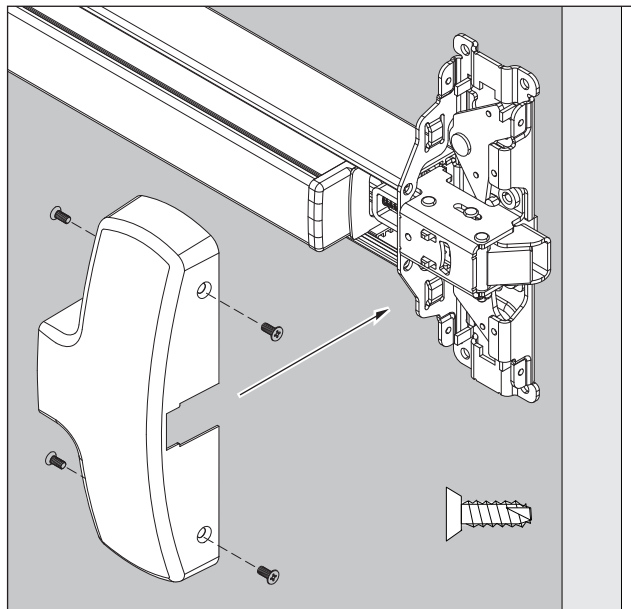

Warnings and Cautions

Warnings look like this:



Cautions look like this:

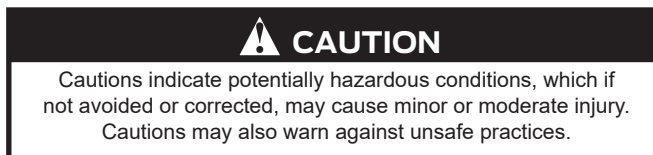

Notices look like this:

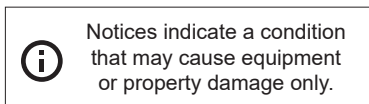

Directions look like this:

